

JVC

SERVICE MANUAL

CD RECEIVER

KW-XR810J, KW-XR816U, KW-XR816UH, KW-XR811E, KW-XR811EY, KW-XR811EU, KW-XR817EE

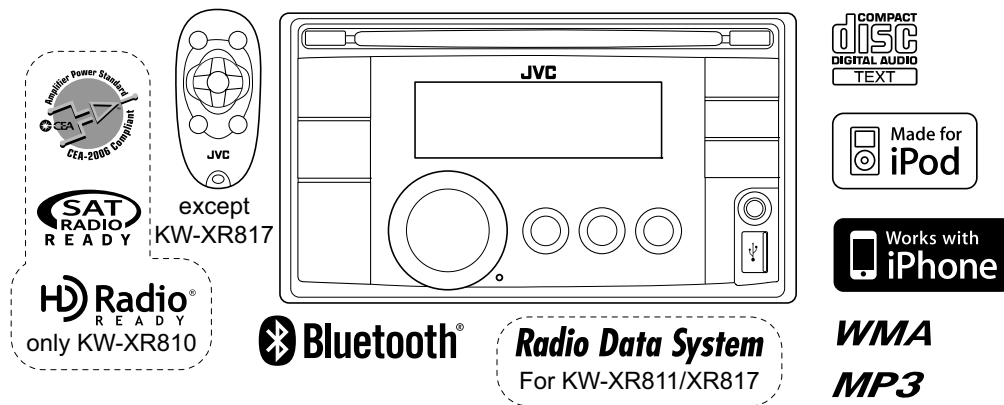

Lead free solder used in the board (material : Sn-Ag-Cu, melting point : 219 Centigrade)
Lead free solder used in the board (material : Sn-Cu, melting point : 230 Centigrade)

TABLE OF CONTENTS

1	PRECAUTION.....	1-5
2	SPECIFIC SERVICE INSTRUCTIONS.....	1-9
3	DISASSEMBLY.....	1-9
4	ADJUSTMENT.....	1-21
5	TROUBLESHOOTING.....	1-24

SPECIFICATION

KW-XR810

KW-XR810		
AUDIO AMPLIFIER SECTION		
Power Output	20 W RMS × 4 Channels at 4 Ω and < 1% THD+N	
Signal-to-Noise Ratio	80 dBA (reference: 1 W into 4 Ω)	
Load Impedance	4 Ω (4Ω to 8 Ω allowance)	
Tone Control Range	Bass	±12 dB (50 Hz, 100 Hz, 200 Hz) Q0.7, Q1.0, Q1.4, Q2.0
	Middle	±12 dB (0.5 kHz, 1.0 kHz, 2.0 kHz) Q0.7, Q1.0, Q1.4, Q2.0
	Treble	±12 dB (5.0 kHz, 10.0 kHz, 15.0 kHz) Q0.7, Q1.0, Q1.4, Q2.0
Frequency Response	40 Hz to 20 000 Hz	
Line-Out Level/Impedance	2.5 V/20 kΩ load (full scale)	
Subwoofer-Out Level/Impedance	2.5 V/20 kΩ load (full scale)	
Output Impedance	1 kΩ	
Other Terminal	AUX (auxiliary) input jack, USB input terminal, USB cable, Antenna input, Expansion port, Steering wheel remote input	
TUNER SECTION		
Frequency Range	FM	with channel interval set to 100 kHz or 200 kHz
		with channel interval set to 50 kHz
	AM	with channel interval set to 10 kHz
		with channel interval set to 9 kHz
FM Tuner	Usable Sensitivity	9.3 dBf (0.8 μV/75 Ω)
	50 dB Quieting Sensitivity	16.3 dBf (1.8 μV/75 Ω)
	Alternate Channel Selectivity (400 kHz)	65 dB
	Frequency Response	40 Hz to 15 000 Hz
	Stereo Separation	40 dB
AM Tuner	Sensitivity	20 μV
	Selectivity	40 dB
CD PLAYER SECTION		
Type	Compact disc player	
Signal Detection System	Non-contact optical pickup (semiconductor laser)	
Number of Channels	2 channels (stereo)	
Frequency Response	5 Hz to 20 000 Hz	
Dynamic Range	96 dB	
Signal-to-Noise Ratio	98 dB	
Wow and Flutter	Less than measurable limit	
MP3 Decoding Format: (MPEG1/2 Audio Layer 3)	Max. Bit Rate: 320 kbps	
WMA (Windows Media® Audio) Decoding Format	Max. Bit Rate: 320 kbps	
USB SECTION		
USB Standard	USB 1.1, USB 2.0	
Data Transfer Rate	Full Speed	Max. 12 Mbps
	Low Speed	Max. 1.5 Mbps
Compatible Device	Mass storage class (except HDD)	
Compatible File System	FAT 32/16/12	
Playable Audio Format	MP3/WMA/WAV	
Max. Current	DC 5 V 500 mA	
BLUETOOTH		
Version	Bluetooth 2.0 certified	
Power Class	Class 2 Radio (possible distance 10 m)	
Service Area	10 m	
Profile	HFP 1.5, OPP 1.1, A2DP 1.2, AVRCP 1.3, PBAP 1.0	
Max. Current	DC 5 V 54.3 mA	
GENERAL		
Power Requirement	Operating Voltage	DC 14.4 V (11 V to 16 V allowance)
Grounding System	Negative ground	
Allowable Operating Temperature	0°C to +40°C (32°F to 104°F)	
Dimensions (W × H × D) (approx.)	Installation Size	182 mm × 111 mm × 160 mm (7-3/16" × 4-3/8" × 6-5/16")
	Panel Size	188 mm × 117 mm × 23 mm (7-7/16" × 4-5/8" × 5/16")
Mass	1.9 kg (4.2 lbs) (excluding accessories)	

Designs & specifications are subject to change without notice.

KW-XR811, KW-XR817		
AUDIO AMPLIFIER SECTION		
Maximum Power Output	Front/Rear	50 W per channel
Continuous Power Output (RMS)	Front/Rear	20 W per channel into 4 Ω , 40 Hz to 20 000 Hz at no more than 1% total harmonic distortion.
Load Impedance		4 Ω (4 Ω to 8 Ω allowance)
Tone Control Range	Bass	± 12 dB (50 Hz, 100 Hz, 200 Hz) Q0.7, Q1.0, Q1.4, Q2.0
	Middle	± 12 dB (0.5 kHz, 1.0 kHz, 2.0 kHz) Q0.7, Q1.0, Q1.4, Q2.0
	Treble	± 12 dB (5.0 kHz, 10.0 kHz, 15.0 kHz) Q0.7, Q1.0, Q1.4, Q2.0
Frequency Response		40 Hz to 20 000 Hz
Signal-to-Noise Ratio		70 dB
Line-Out Level/Impedance		2.5 V/20 k Ω load (full scale)
Subwoofer-Out Level/Impedance		2.5 V/20 k Ω load (full scale)
Output Impedance		1 k Ω
Other Terminal		AUX (auxiliary) input jack, USB input terminal, USB cable, Aerial input, Steering wheel remote input(KW-XR811)
TUNER SECTION		
Frequency Range	FM	87.5 MHz to 108.0 MHz
	FM-LOW (KW-XR817)	65.0 MHz to 74.0 MHz
	AM	MW: 522 kHz to 1 620 kHz LW: 144 kHz to 279 kHz
FM Tuner	Usable Sensitivity	9.3 dBf (0.8 μ V/75 Ω)
	50 dB Quieting Sensitivity	16.3 dBf (1.8 μ V/75 Ω)
	Alternate Channel Selectivity (400 kHz)	65 dB
	Frequency Response	40 Hz to 15 000 Hz
	Stereo Separation	40 dB
MW Tuner	Sensitivity	20 μ V
AM Tuner	Selectivity	40 dB
	Sensitivity	50 μ V
CD PLAYER SECTION		
Type		Compact disc player
Signal Detection System		Non-contact optical pickup (semiconductor laser)
Number of Channels		2 channels (stereo)
Frequency Response		5 Hz to 20 000 Hz
Dynamic Range		96 dB
Signal-to-Noise Ratio		98 dB
Wow and Flutter		Less than measurable limit
MP3 Decoding Format: (MPEG1/2 Audio Layer 3)		Max. Bit Rate: 320 kbps
WMA (Windows Media® Audio) Decoding Format		Max. Bit Rate: 320 kbps
USB SECTION		
USB Standard		USB 1.1, USB 2.0
Data Transfer Rate	Full Speed	Max. 12 Mbps
	Low Speed	Max. 1.5 Mbps
Compatible Device		Mass storage class (except HDD)
Compatible File System		FAT 32/16/12
Playable Audio Format		MP3/WMA/WAV
Max. Current		DC 5 V 500 mA
BLUETOOTH		
Version		Bluetooth 2.0 certified
Power Class		Class 2 Radio (possible distance 10 m)
Service Area		10 m
Profile		HFP 1.5, OPP 1.1, A2DP 1.2, AVRCP 1.3, PBAP 1.0
Max. Current		DC 5 V 54.3 mA
GENERAL		
Power Requirement	Operating Voltage	DC 14.4 V (11 V to 16 V allowance)
Grounding System		Negative ground
Allowable Operating Temperature		0°C to +40°C
Dimensions (W \times H \times D): (approx.)	Installation Size	182 mm \times 111 mm \times 160 mm
	Panel Size	188 mm \times 117 mm \times 23 mm
Mass		1.9 kg (excluding accessories)

Designs & specifications are subject to change without notice.

KW-XR816**AUDIO AMPLIFIER SECTION**

Maximum Power Output	Front/Rear	50 W per channel
Continuous Power Output (RMS)	Front/Rear	20 W per channel into 4 Ω , 40 Hz to 20 000 Hz at no more than 1% total harmonic distortion.
Load Impedance		4 Ω (4 Ω to 8 Ω allowance)
Tone Control Range	Bass	± 12 dB (50 Hz, 100 Hz, 200 Hz) Q0.7, Q1.0, Q1.4, Q2.0
	Middle	± 12 dB (0.5 kHz, 1.0 kHz, 2.0 kHz) Q0.7, Q1.0, Q1.4, Q2.0
	Treble	± 12 dB (5.0 kHz, 10.0 kHz, 15.0 kHz) Q0.7, Q1.0, Q1.4, Q2.0
Frequency Response		40 Hz to 20 000 Hz
Signal-to-Noise Ratio		70 dB
Line-Out Level/Impedance		5.0 V/20 k Ω load (full scale)
Subwoofer-Out Level/Impedance		5.0 V/20 k Ω load (full scale)
Output Impedance		1 k Ω
Other Terminal		AUX (auxiliary) input jack, USB input terminal, USB rear cable, Antenna input, Steering wheel remote input

TUNER SECTION

Frequency Range	FM	87.5 MHz to 108.0 MHz
	AM	MW: 522 kHz to 1 620 kHz LW: 144 kHz to 279 kHz
FM Tuner	Usable Sensitivity	9.3 dBf (0.8 μ V/75 Ω)
	50 dB Quieting Sensitivity	16.3 dBf (1.8 μ V/75 Ω)
	Alternate Channel Selectivity (400 kHz)	65 dB
	Frequency Response	40 Hz to 15 000 Hz
	Stereo Separation	40 dB
AM Tuner	Sensitivity	20 μ V
	Selectivity	40 dB

CD PLAYER SECTION

Type	Compact disc player
Signal Detection System	Non-contact optical pickup (semiconductor laser)
Number of Channels	2 channels (stereo)
Frequency Response	5 Hz to 20 000 Hz
Dynamic Range	96 dB
Signal-to-Noise Ratio	98 dB
Wow and Flutter	Less than measurable limit
MP3 Decoding Format: (MPEG1/2 Audio Layer 3)	Max. Bit Rate: 320 kbps
WMA (Windows Media® Audio) Decoding Format	Max. Bit Rate: 320 kbps

USB SECTION

USB Standard	USB 1.1, USB 2.0	
Data Transfer Rate	Full Speed	Max. 12 Mbps
	Low Speed	Max. 1.5 Mbps
Compatible Device	Mass storage class (except HDD)	
Compatible File System	FAT 32/16/12	
Playable Audio Format	MP3/WMA/WAV	
Max. Current	DC 5 V 500 mA	

BLUETOOTH

Version	Bluetooth 2.0 certified
Power Class	Class 2 Radio (possible distance 10 m)
Service Area	10 m
Profile	HFP 1.5, OPP 1.1, A2DP 1.2, AVRCP 1.3, PBAP 1.0
Max. Current	DC 5 V 54.3 mA

GENERAL

Power Requirement	Operating Voltage	DC 14.4 V (11 V to 16 V allowance)
Grounding System		Negative ground
Allowable Operating Temperature		0°C to +40°C
Dimensions (W × H × D): (approx.)	Installation Size	182 mm × 111 mm × 160 mm
	Panel Size	188 mm × 117 mm × 23 mm
Mass		1.6 kg (excluding accessories)

Designs & specifications are subject to change without notice.

SECTION 1 PRECAUTION

1.1 Safety Precautions

- (1) This design of this product contains special hardware and many circuits and components specially for safety purposes. For continued protection, no changes should be made to the original design unless authorized in writing by the manufacturer. Replacement parts must be identical to those used in the original circuits. Services should be performed by qualified personnel only.
- (2) Alterations of the design or circuitry of the product should not be made. Any design alterations of the product should not be made. Any design alterations or additions will void the manufacturer's warranty and will further relieve the manufacturer of responsibility for personal injury or property damage resulting therefrom.
- (3) Many electrical and mechanical parts in the products have special safety-related characteristics. These characteristics are often not evident from visual inspection nor can the protection afforded by them necessarily be obtained by using replacement components rated for higher voltage, wattage, etc. Replacement parts which have these special safety characteristics are identified in the Parts List of Service Manual. Electrical components having such features are identified by shading on the schematics and by (Δ) on the Parts List in the Service Manual. The use of a substitute replacement which does not have the same safety characteristics as the recommended replacement parts shown in the Parts List of Service Manual may create shock, fire, or other hazards.
- (4) The leads in the products are routed and dressed with ties, clamps, tubings, barriers and the like to be separated from live parts, high temperature parts, moving parts and/or sharp edges for the prevention of electric shock and fire hazard. When service is required, the original lead routing and dress should be observed, and it should be confirmed that they have been returned to normal, after reassembling.
- (5) Leakage shock hazard testing

After reassembling the product, always perform an isolation check on the exposed metal parts of the product (antenna terminals, knobs, metal cabinet, screw heads, headphone jack, control shafts, etc.) to be sure the product is safe to operate without danger of electrical shock. Do not use a line isolation transformer during this check.

 - Plug the AC line cord directly into the AC outlet. Using a "Leakage Current Tester", measure the leakage current from each exposed metal part of the cabinet, particularly any exposed metal part having a return path to the chassis, to a known good earth ground. Any leakage current must not exceed 0.5mA AC (r.m.s.).
 - Alternate check method
Plug the AC line cord directly into the AC outlet. Use an AC voltmeter having, 1,000 Ω per volt or more sensitivity in the following manner. Connect a 1,500 Ω 10W resistor paralleled by a 0.15 μ F AC-type capacitor between an exposed metal part and a known good earth ground. Measure the AC voltage across the resistor with the AC

voltmeter.

Move the resistor connection to each exposed metal part, particularly any exposed metal part having a return path to the chassis, and measure the AC voltage across the resistor. Now, reverse the plug in the AC outlet and repeat each measurement. Voltage measured any must not exceed 0.75 V AC (r.m.s.). This corresponds to 0.5 mA AC (r.m.s.).

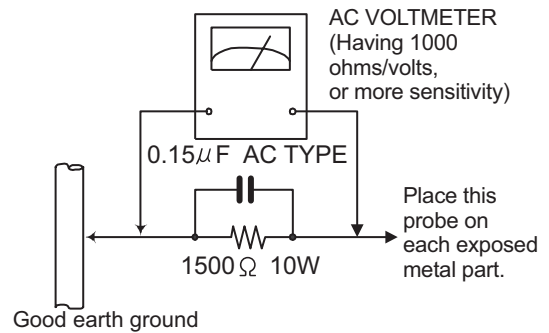

1.2 Warning

- (1) This equipment has been designed and manufactured to meet international safety standards.
- (2) It is the legal responsibility of the repairer to ensure that these safety standards are maintained.
- (3) Repairs must be made in accordance with the relevant safety standards.
- (4) It is essential that safety critical components are replaced by approved parts.
- (5) If mains voltage selector is provided, check setting for local voltage.

1.3 Caution

Burrs formed during molding may be left over on some parts of the chassis.

Therefore, pay attention to such burrs in the case of pre-forming repair of this system.

1.4 Critical parts for safety

In regard with component parts appearing on the silk-screen printed side (parts side) of the PWB diagrams, the parts that are printed over with black such as the resistor (■), diode (■) and ICP (●) or identified by the " Δ " mark nearby are critical for safety. When replacing them, be sure to use the parts of the same type and rating as specified by the manufacturer. (This regulation does not Except the J and C version)

1.5 Preventing static electricity

Electrostatic discharge (ESD), which occurs when static electricity stored in the body, fabric, etc. is discharged, can destroy the laser diode in the traverse unit (optical pickup). Take care to prevent this when performing repairs.

1.5.1 Grounding to prevent damage by static electricity

Static electricity in the work area can destroy the optical pickup (laser diode) in devices such as laser products. Be careful to use proper grounding in the area where repairs are being performed.

(1) Ground the workbench

Ground the workbench by laying conductive material (such as a conductive sheet) or an iron plate over it before placing the traverse unit (optical pickup) on it.

(2) Ground yourself

Use an anti-static wrist strap to release any static electricity built up in your body.

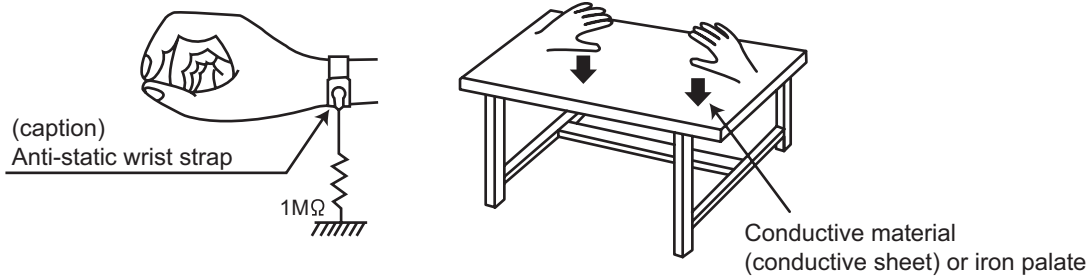

(3) Handling the optical pickup

- In order to maintain quality during transport and before installation, both sides of the laser diode on the replacement optical pickup are shorted. After replacement, return the shorted parts to their original condition. (Refer to the text.)
- Do not use a tester to check the condition of the laser diode in the optical pickup. The tester's internal power source can easily destroy the laser diode.

1.6 Handling the traverse unit (optical pickup)

- (1) Do not subject the traverse unit (optical pickup) to strong shocks, as it is a sensitive, complex unit.
- (2) Cut off the shorted part of the flexible cable using nippers, etc. after replacing the optical pickup. For specific details, refer to the replacement procedure in the text. Remove the anti-static pin when replacing the traverse unit. Be careful not to take too long a time when attaching it to the connector.
- (3) Handle the flexible cable carefully as it may break when subjected to strong force.
- (4) It is not possible to adjust the semi-fixed resistor that adjusts the laser power. Do not turn it.

1.7 Attention when traverse unit is decomposed

***Please refer to "Disassembly method" in the text for the pickup unit.**

- Apply solder to the short land sections before the card wire is disconnected from the connector on the servo board. (If the card wire is disconnected without applying solder, the pickup may be destroyed by static electricity.)
- In the assembly, be sure to remove solder from the short land sections after connecting the card wire.

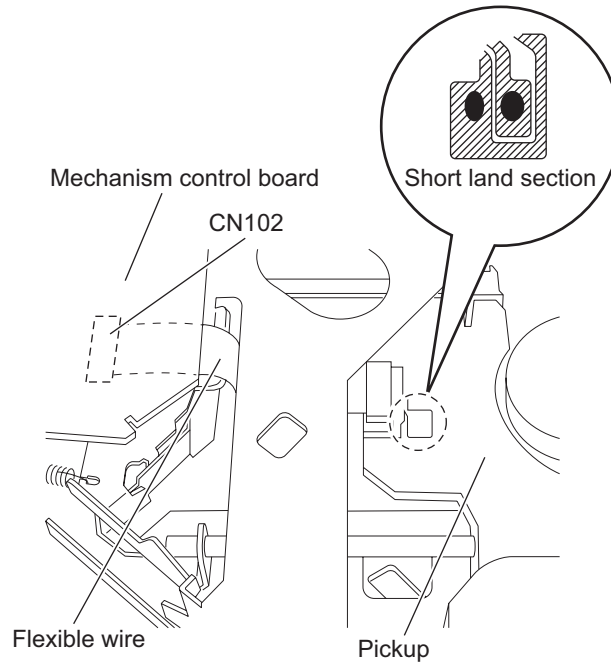

1.8 Important for laser products

1.CLASS 1 LASER PRODUCT

2.CAUTION :

(For U.S.A.) Visible and/or invisible class II laser radiation when open. Do not stare into beam.

(Others) Visible and/or invisible class 1M laser radiation when open. Do not view directly with optical instruments.

3.CAUTION : Visible and/or invisible laser radiation when open and inter lock failed or defeated. Avoid direct exposure to beam.

4.CAUTION : This laser product uses visible and/or invisible laser radiation and is equipped with safety switches which prevent emission of radiation when the drawer is open and the safety interlocks have failed or are defeated. It is dangerous to defeat the safety switches.

(For U.S.A.)

CAUTION : Visible and/or invisible class II laser radiation when open. Do not stare into beam.

(Others)

CAUTION : Visible and/or invisible class 1M laser radiation when open. Do not view directly with optical instruments

ACHTUNG: Sichtbare und/oder unsichtbare Laserstrahlung der Klasse 1M bei offenen Abdeckungen. Nicht direkt mit optischen Instrumenten betrachten.

ATTENTION: Rayonnement laser visible et/ou invisible de classe 1M une fois ouvert. Ne pas regarder directement avec des instruments optiques.

VOORZICHTIG: Zichtbare en/of onzichtbare klasse 1M laserstralen indien geopend. Bekijk niet direct met optische instrumenten.

ATTENZIONE: Radiazione laser in classe 1M visibile e/o invisibile quando aperto. Non osservare direttamente con strumenti ottici.

WARNING: Synlig och/eller osynlig laserstrålning, klass 1M, när denna del är öppnad. Betrakta ej strålen med optiska instrument.

VARO! Avattaessa olet alttiina nakyyvalle ja/tai näkymättömälle luokan 1M lasersateilylle. Älä tarkastele sitä optisen laitteen läpi.

ADVASEL: Synlig og/eller usynlig klasse 1M-laserstråling ved åbning. Se ikke direkte med optiske instrumenter.

AVISO: Radiación láser de clase 1M visible y/o invisible cuando está abierto. No mirar directamente con instrumental óptico.

PRECAUÇÃO: Radiação laser de classe 1M visível e/ou invisível quando aberto. Não olhe diretamente com instrumentos ópticos.

5.CAUTION : If safety switches malfunction, the laser is able to function.

6.CAUTION : Use of controls, adjustments or performance of procedures other than those specified here in may result in hazardous radiation exposure.



CAUTION Please use enough caution not to see the beam directly or touch it in case of an adjustment or operation check.

PRECAUÇÃO: Radiação laser de classe 1M visível e/ou invisível quando aberto. Não olhe diretamente com instrumentos ópticos.

ПРЕДУПРЕЖДЕНИЕ: В открытом состоянии происходит видимое и/или невидимое излучение лазера класса 1M. Не смотрите непосредственно в оптические инструменты.

UWAGA: Otwarcie spowoduje narażenie na widzialne i/lub niewidzialne promieniowanie lasera klasy 1M. Nie patrzeć bezpośrednio w przyrządy optyczne.

UPOZORNĚNÍ: Při otevření vydává viditelné popř. neviditelné laserové ozáření třídy 1M. Nedívejte se do otvoru přímo s optickými nástroji.

FIGYELMEZTETÉS: Látható és/vagy láthatatlan 1M osztályú sugárzás nyitott állapotban. Ne nézze közvetlenül optikai műszerekkel.

注意: 打開蓋板可能會產生可見或不可見的 1M 級鐳射。不要使用光學儀器直接進行窺視。

注意: 打开蓋板可能会产生可见或不可见的 1M 级辐射。不要使用光学仪器直接进行窥视。

تنبيه: يوجد إشعاع ليزري مرئي و/أو غير مرئي من الفئة 1M عندما يكون الجهاز مفتوحاً. تجنب النظر مباشرة داخل الجهاز باستخدام أدوات بصرية.

احتياط: هنگامی که باز گردد، تشعشع مرئی و یا نامرئی کلاس 1M لیزر وجود دارد. با لوازم چشمی مستقیماً به آن نگاه نکنید.

주의: 개방하면 가시 및/또는 비가시 클래스 1M 레이저 방사선이 나옵니다. 광학 기구로 직접 들여다보지 마십시오.

REPRODUCTION AND POSITION OF LABELS and PRINT WARNING LABEL and PRINT



CAUTION VISIBLE AND/OR INVISIBLE CLASS 1M LASER RADIATION WHEN OPEN. DO NOT VIEW DIRECTLY WITH OPTICAL INSTRUMENTS. IEC60825-1:2001 (ENG)	ATTENTION RAYONNEMENT LASER VISIBLE ET/OU INVISIBLE DE CLASSE 1M UNE FOIS OUVERT. NE PAS REGARDER DIRECTEMENT AVEC DES INSTRUMENTS OPTIQUES. (FRA)	AVISO RADIACIÓN LASER DE CLASE 1M VISIBLE Y/O INVISIBLE CUANDO ESTÁ ABIERTO. NO MIRAR DIRECTAMENTE CON INSTRUMENTAL ÓPTICO. (ESP)	WARNING SYNLIG OCH/ELLER OSYNLIG LASERSTRÅLNING, KLASS 1M, NÄR DENNA DEL ÄR ÖPPNAD. BETRAKTA EJ STRÅLEN MED OPTISKA INSTRUMENT. (SWE)	注意 ニモ可視と不可視 及び/または不可視 のクラス1M レーザー放射が 出ます。 光学観望で直接 見ないでください。 (JPN)	CAUTION VISIBLE AND/OR INVISIBLE CLASS II LASER RADIATION WHEN OPEN. DO NOT STARE INTO BEAM. FDA 21 CFR (ENG) LV44633-003A
--	--	---	---	--	---

SECTION 2 SPECIFIC SERVICE INSTRUCTIONS

This service manual does not describe SPECIFIC SERVICE INSTRUCTIONS.

SECTION 3 DISASSEMBLY

3.1 Main body (Used model: KW-XR610)

3.1.1 Removing the Front panel (See Fig.1)

- (1) Remove the two screws **A** attaching the both side of the Front panel.
- (2) Disengage four hooks **a** engaged both side of the Front panel.

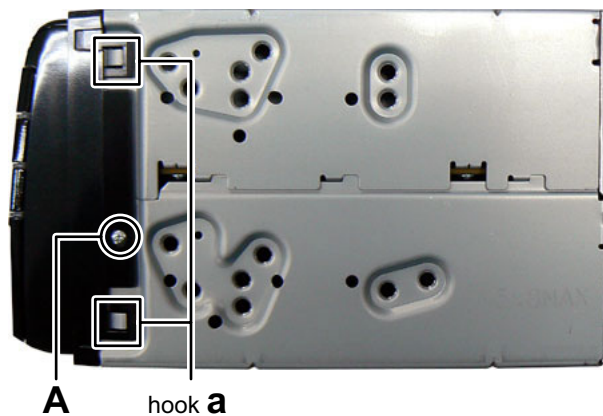

Fig.1

3.1.2 Removing the Bottom chassis (See Fig.2, 3)

- (1) Remove the two screws **B** attaching the both side of the Bottom chassis. (See Fig.2)



Fig.2

- (2) Remove the three screws **C** attaching the Bottom chassis. (See Fig.3)
- (3) Remove the three screws **D** and one screw **E** attaching the Heat sink. (See Fig.3)
- (4) Remove the six screws **F** and one screw **G** attaching the Rear bracket. (See Fig.3)

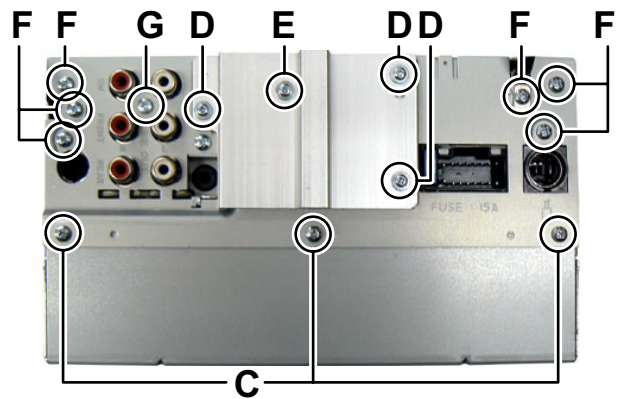

Fig.3

3.1.3 Removing the Main board (See Fig.4, 5)

- (1) Remove the two screws **H** and one screw **J** attaching the Side plate. (See Fig.4)

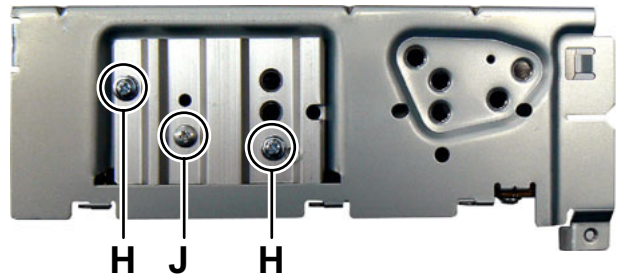

Fig.4

- (2) Remove the three screws **K** attaching the Main board. (See Fig.5)
- (3) Disconnect B-B connector [CN501](#) of the Main board connected the CD mechanism and Main board. (See Fig.5)

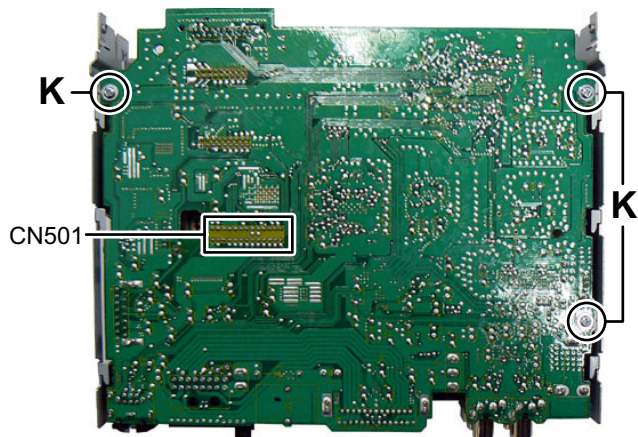

Fig.5

3.1.4 Removing the CD mechanism (See Fig.6)

- (1) Remove the three screws **L** attaching the CD mechanism.

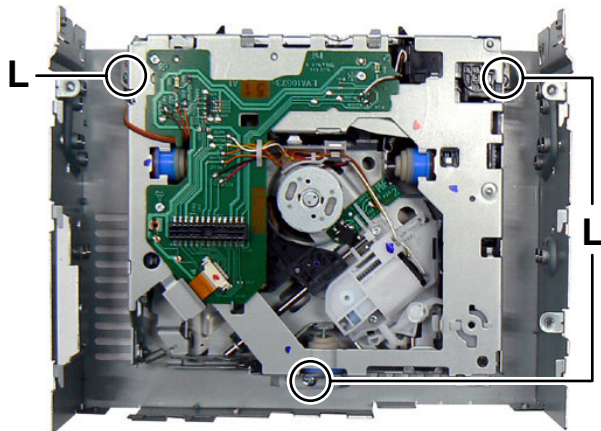

Fig.6

3.1.5 Removing the Switch board (See Fig.7)

- (1) Remove the Volume knob.
- (2) Disconnect the flexible wire from LCD connected to connector [CN602](#) of the Switch board.
- (3) Remove the sixteen screws **M** attaching the Switch board.

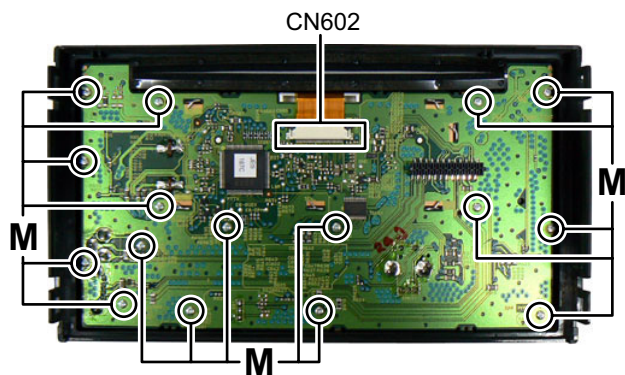

Fig.7

3.2 CD MECHANISM assembly section

- Remove the CD MECHANISM assembly from the main body.

3.2.1 Removing the MECHANISM CONTROL BOARD assembly (See Fig.1 and 2)

- From the bottom side of CD MECHANISM assembly, remove the solders from the soldered sections (a, b and c) on the MECHANISM CONTROL BOARD assembly. (See Fig.1.)
- Remove the three screws **A** and one screw **B** attaching the MECHANISM CONTROL BOARD assembly. (See Fig.1.)
- Solder the short land sections on the pickup. (See Fig.2.)

Caution:

- Solder the short land sections on the pickup before disconnecting the flexible wire from the connector **CN102** on the MECHANISM CONTROL BOARD assembly.
If the card wire is disconnected without attaching solder, the pickup may be destroyed by static electricity. (See Fig.2.)
- When attaching the MECHANISM CONTROL BOARD assembly, remove the solders from the short land sections after connecting the flexible wire to the connector **CN102** on the MECHANISM CONTROL BOARD assembly.

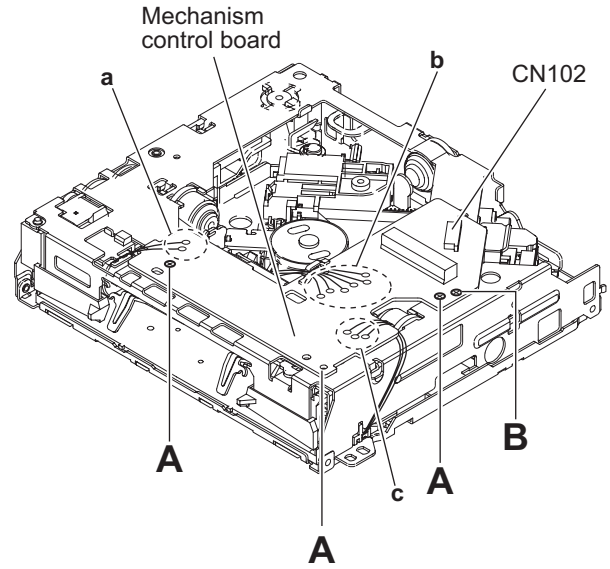

Fig.1

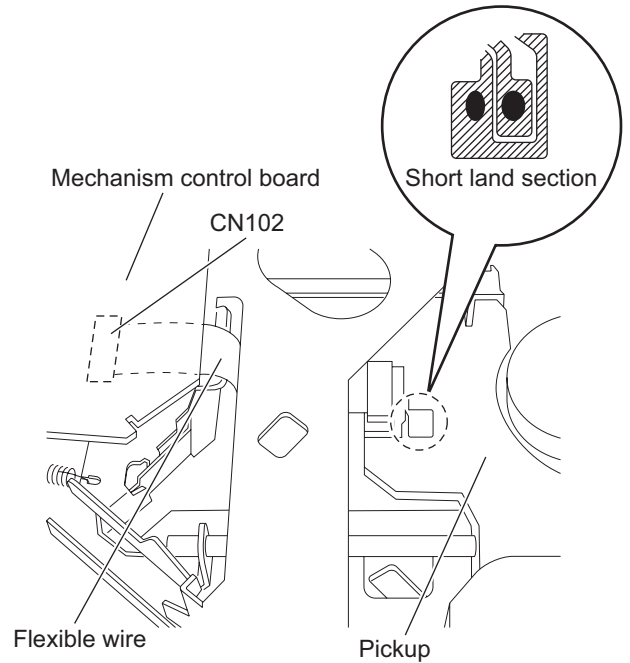
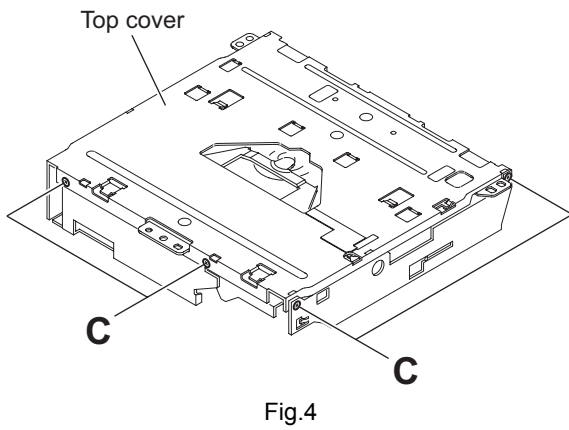
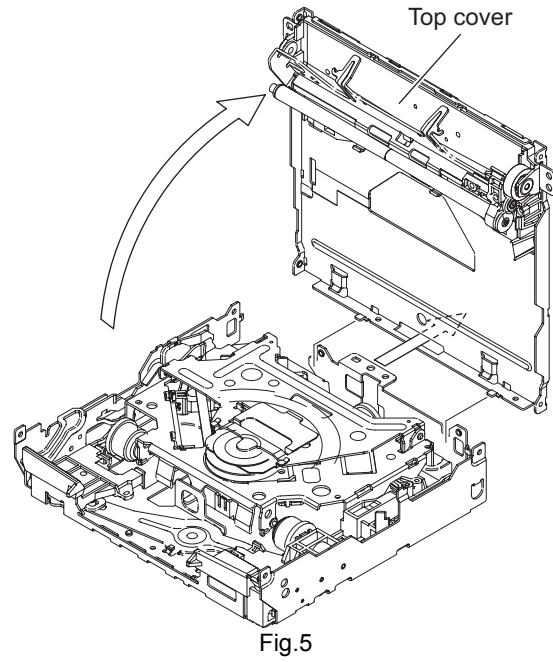
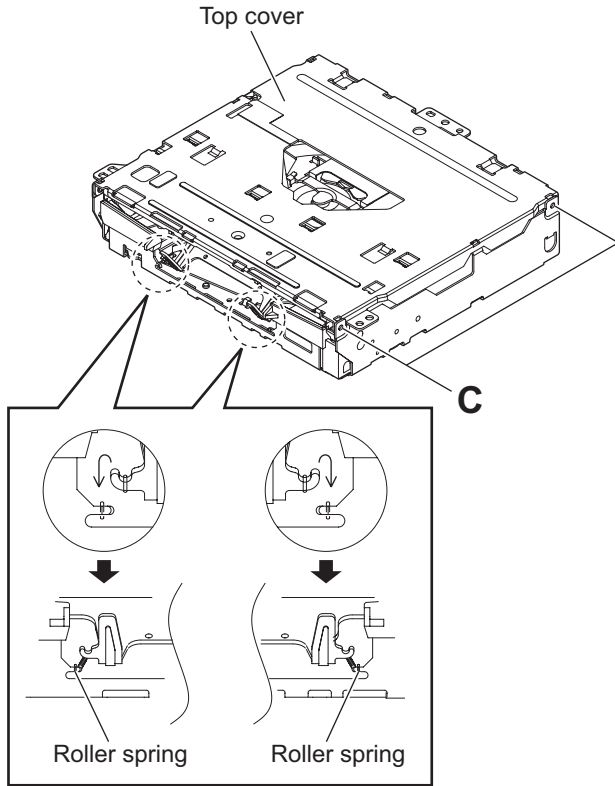

Fig.2

3.2.2 Removing the top cover (See Fig.3 to 5)

• Remove the MECHANISM CONTROL BOARD assembly.

- (1) From the front side of the CD MECHANISM assembly, change the hook position of the two roller springs. (See Fig.3.)
- (2) From the side of the CD MECHANISM assembly, remove the six screws **C** attaching the top cover. (See Fig.3 and 4.)
- (3) Take out the top cover in an upward direction. (See Fig.5.)



3.2.3 Removing the roller (See Fig.6)

- Remove the MECHANISM CONTROL BOARD assembly and top cover.
- (1) From the bottom side of the top cover, remove the screw **D** attaching the gear holder.
- (2) Remove the R.holder assembly from disc plate, and then take out the roller from R.holder assembly in the direction of the arrow.

Reference:

When attaching the R.ACT gear (2) and R.ACT gear (3), apply grease to the section **d** of R.holder assembly.

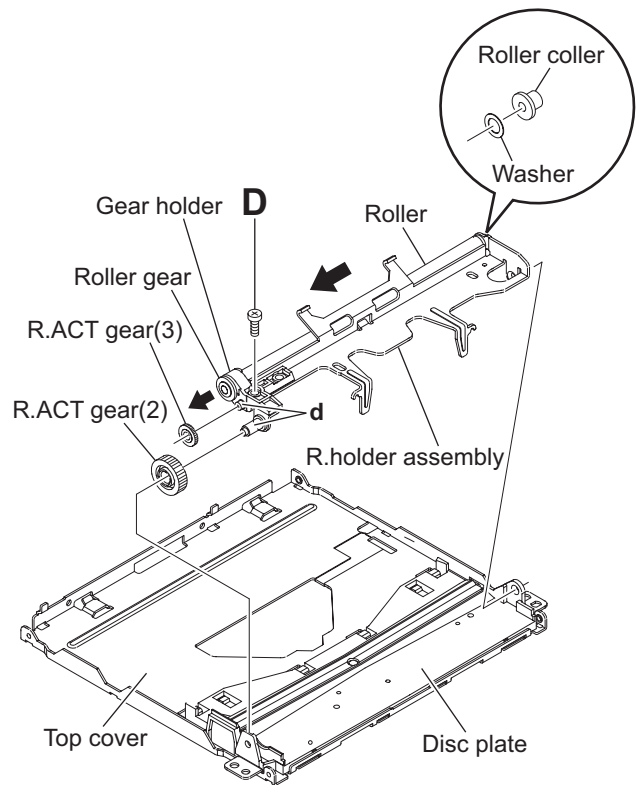

Fig.6

3.2.4 Removing the PHOTO BOARD assembly (See Fig.7 and 8)

- Remove the MECHANISM CONTROL BOARD assembly and top cover.
- (1) From the bottom side of the top cover, release the projection **e** from the notch of the disc plate. (See Fig.7.)
- (2) Take out the disc plate in the direction of the arrow. (See Fig.7.)
- (3) From the reverse side of the disc plate, remove the screw **E** attaching the PHOTO BOARD assembly. (See Fig.8.)

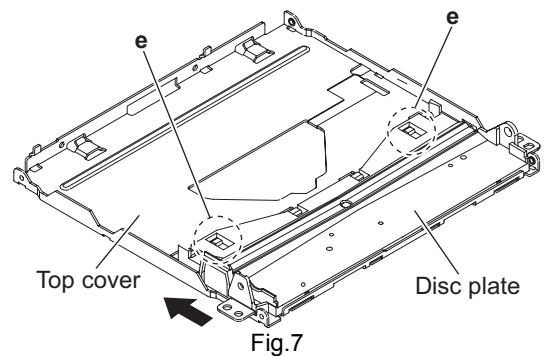

Fig.7

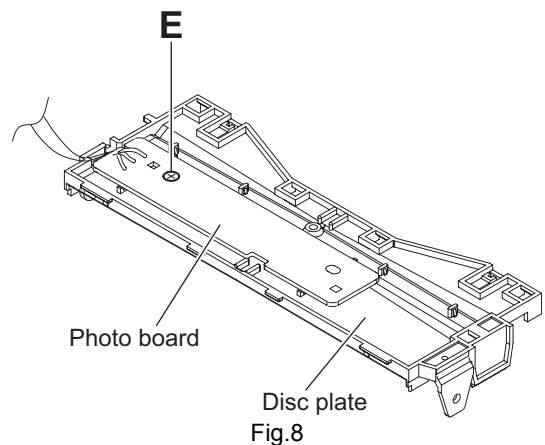

Fig.8

3.2.5 Removing the mechanism section (See Fig.9 and 10)

- Remove the MECHANISM CONTROL BOARD assembly and top cover.

- (1) From the top side of the CD MECHANISM assembly, remove the two screws **F** attaching the loading motor assembly. (See Fig.9.)
- (2) Remove the two roller springs on the top side of the mecha frame. (See Fig.9.)
- (3) Remove the four SUS springs on the top side of the mecha frame. (See Fig.9.)
- (4) Remove the link spring on the top side of the mecha frame. (See Fig.10.)
- (5) Release section **f** of the three dampers from the mecha frame. (See Fig.10.)

Reference:

When attaching the roller spring and SUS spring, keep direction before remove.

- (6) Move the slide cam (R) assembly in the direction of the arrow, and then take out the mechanism section in an upward direction. (See Fig.10.)

Reference:

When attaching the mechanism section, apply grease to the section **g**. (See Fig.10.)

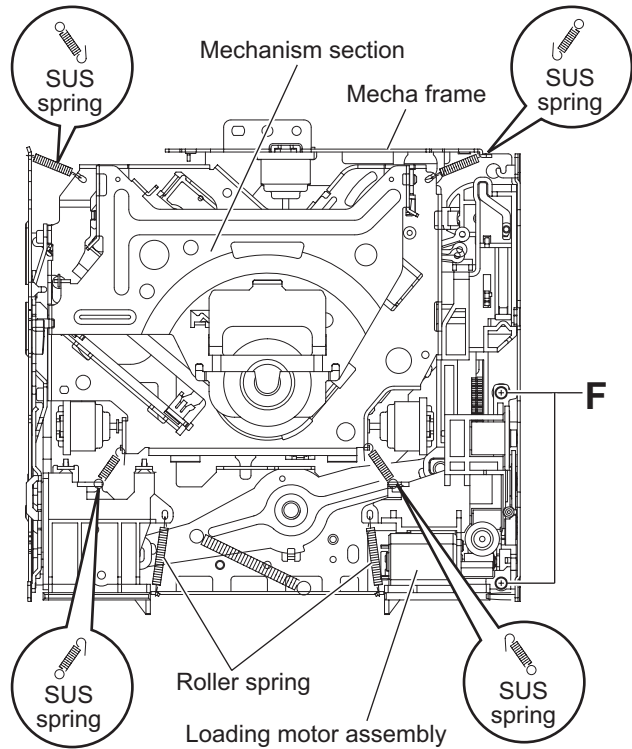

Fig.9

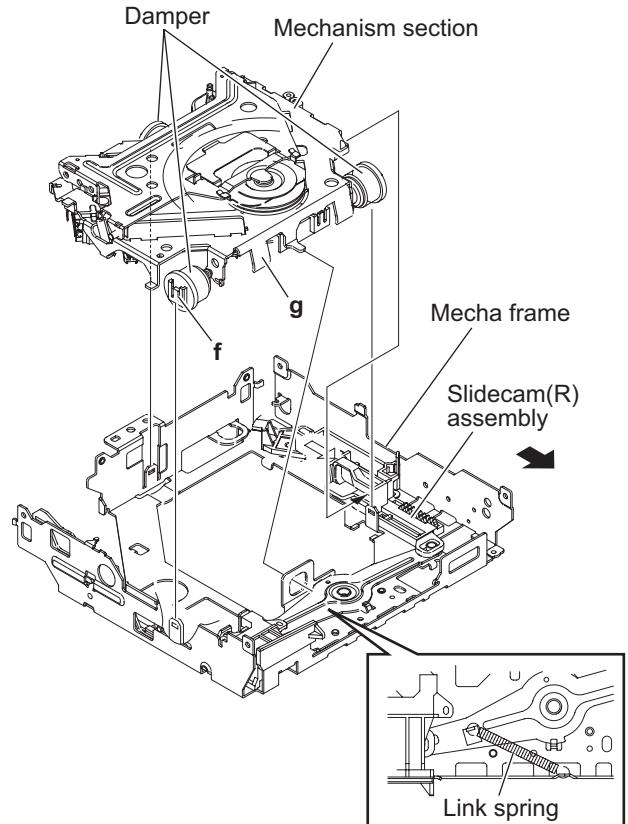

Fig.10

3.2.6 Removing the slide cam (L) (See Fig.11 to 13)

- Remove the MECHANISM CONTROL BOARD assembly, top cover and mechanism section.
 - From the top side of the mecha frame, remove the screw **G** attaching the cam cover. (See Fig.11.)
 - Take out the cam cover from mecha frame in an upward direction. (See Fig.11.)
 - Take out the slide cam (L) in the direction of the arrow. (See Fig.12.)

Reference:

When attaching the slide cam (L), apply grease to the section **h**. (See Fig.13.)

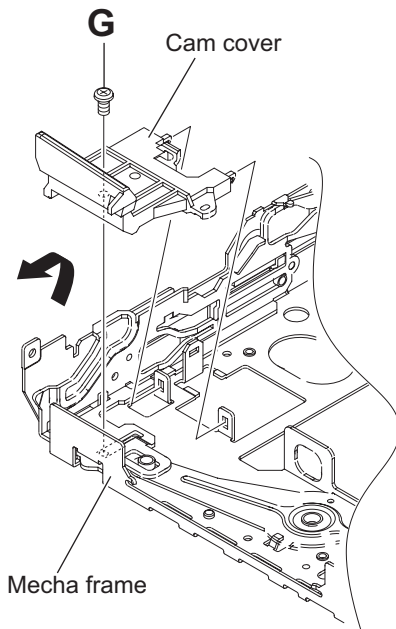

Fig.11

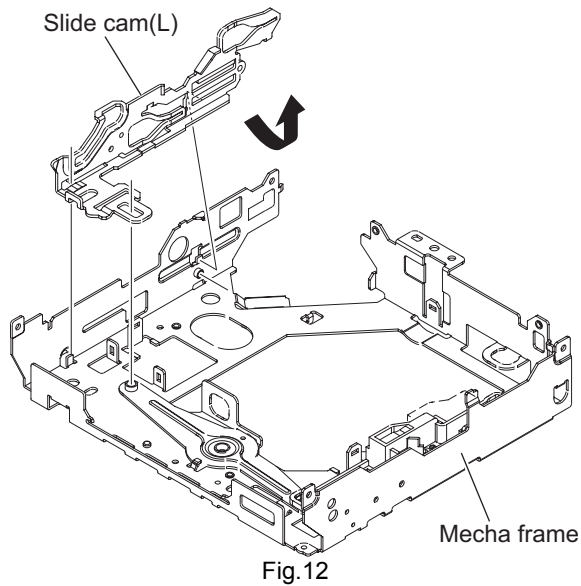

Fig.12

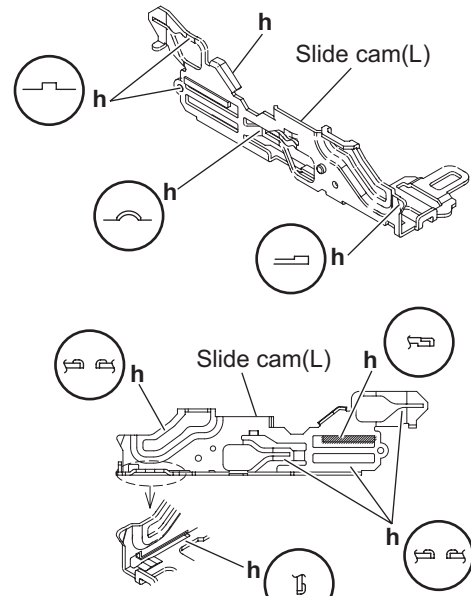

Fig.13

3.2.7 Removing the F.lock lever and slide cam (R) (See Fig.14 and 15)

- Remove the MECHANISM CONTROL BOARD assembly, top cover and mechanism section.
 - From the top side of the mecha frame, take out the slide cam (R) assembly in an upward direction. (See Fig.14.)
 - Rotate the F.lock lever in the direction of the arrow 1, and then take out the direction of the arrow 2. (See Fig.14.)

Reference:

When attaching the slide cam (R) assembly, the f.lock lever and the link arm apply grease to the section **h**. (See Fig.14 and 15.)

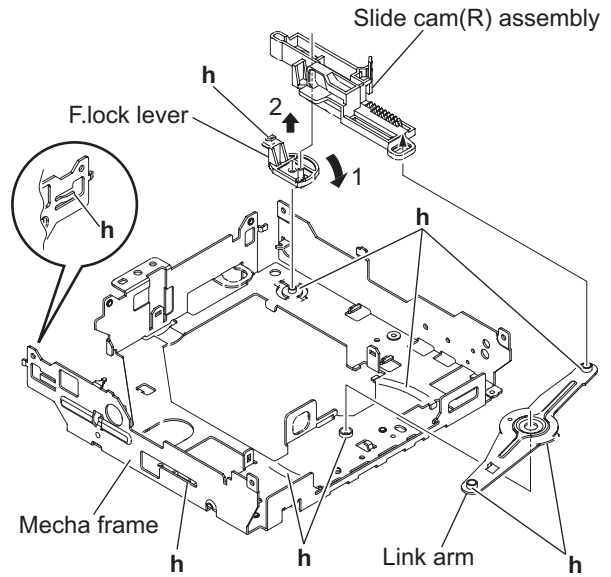

Fig.14

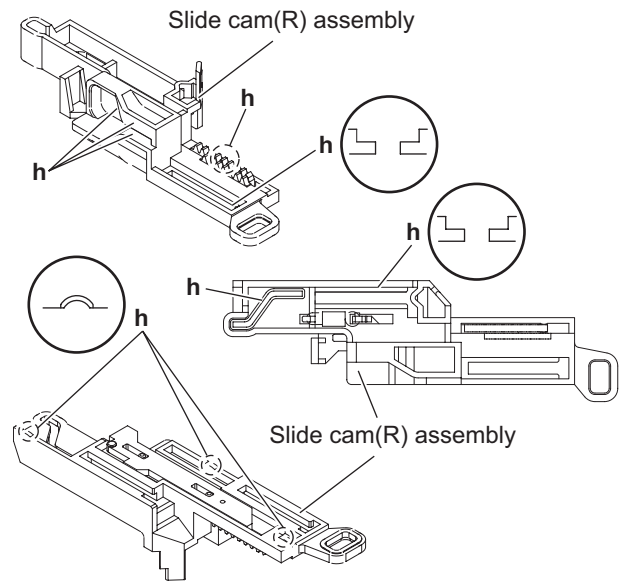

Fig.15

3.2.8 Removing the damper (See Fig.16)

- Remove the MECHANISM CONTROL BOARD assembly, top cover and mechanism section.

From the mechanism section, pull out the three dampers in the direction of the arrow.

Reference:

Before inserting the shaft to the dampers, apply IPA to the pocket **j** of damper.

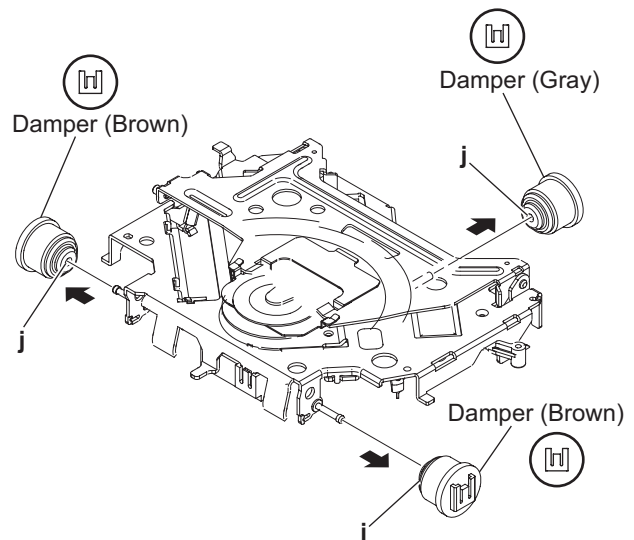

Fig.16

3.2.9 Removing the clamber assembly (See Fig.17)

- Remove the MECHANISM CONTROL BOARD assembly, top cover and mechanism section.
 - From the top side of the mechanism section, release the clamber spring.
 - Move the clamber assembly in the direction of the arrow, and then release the joints (**k** and **m**).
 - Take out the clamber assembly from the T.M chassis assembly.

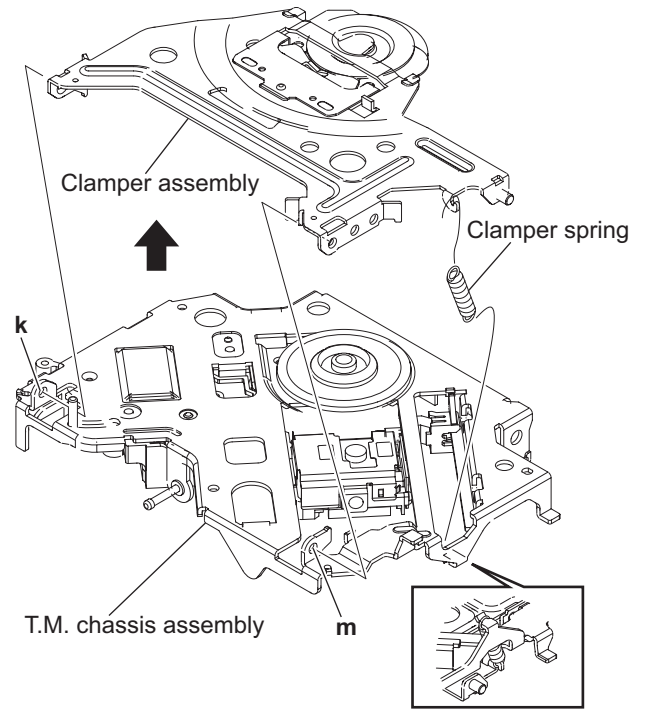

Fig.17

3.2.10 Removing the feed motor (See Fig.18 and 19)

- Remove the MECHANISM CONTROL BOARD assembly, top cover, mechanism section and clamber assembly.
 - From the bottom side of the T.M chassis assembly, remove the two screws **H** attaching the feed motor assembly. (See Fig.18.)
 - Remove the two screws **J** attaching the feed motor to f.motor holder. (See Fig.19.)

Reference:

When attaching the f. wheel gear, trigger arm and feed motor, apply grease to the sections (**n**, **p** and **q**). (See Fig.18 and 19.)

3.2.11 Removing the SWITCH BOARD assembly (See Fig.18)

- Remove the MECHANISM CONTROL BOARD assembly, top cover, mechanism section, clamber assembly and feed motor assembly.

From the bottom side of the T.M chassis assembly, take out the SWITCH BOARD assembly in an upward direction from T.M chassis assembly.

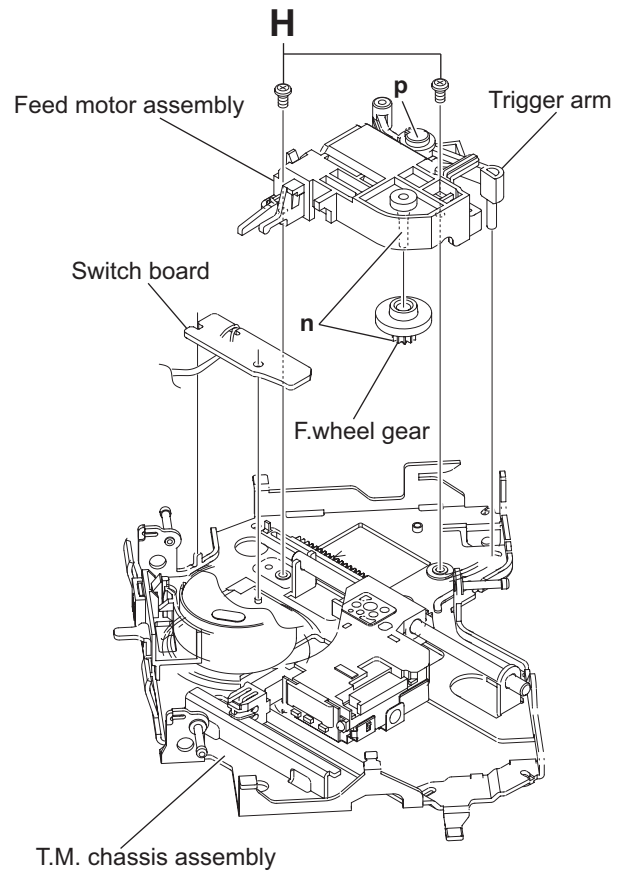

Fig.18

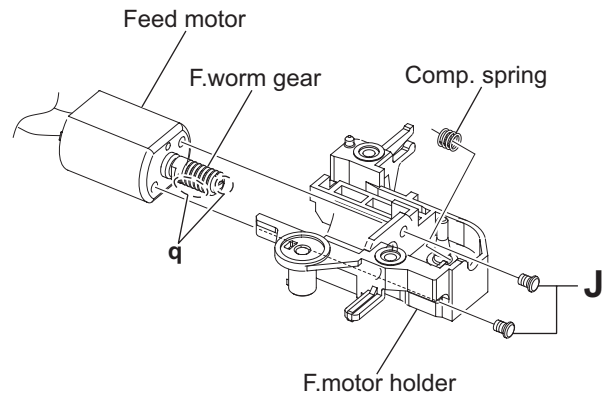

Fig.19

3.2.12 Removing the loading motor (See Fig.20)

- Remove the MECHANISM CONTROL BOARD assembly, top cover, mechanism section and clamber assembly.
 - From the right side of the L.M base assembly, remove the two screws **K** attaching the loading motor.
 - Take out the loading motor in the direction of the arrow from the L.M base assembly.

Reference:

When attaching the loading motor, apply grease to the section **r**.

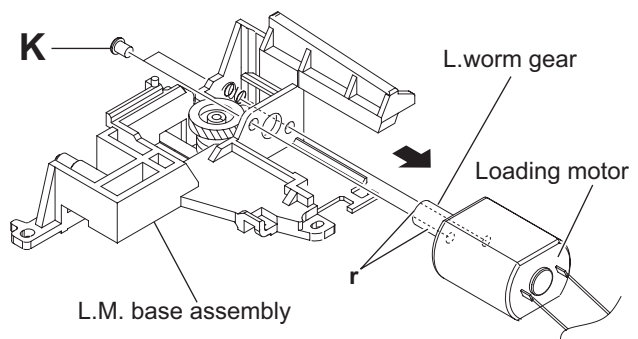

Fig.20

3.2.13 Removing the pickup assembly (See Fig.21 to 22)

- Remove the MECHANISM CONTROL BOARD assembly, top cover, mechanism section, clamper assembly and feed motor assembly.

Caution:

- Do not touch section **u** on the pickup assembly. (See Fig.21 and 22.)
- From the bottom side of the T.M chassis assembly, move the pickup assembly in the direction of the arrow from the T.M chassis assembly. (See Fig.21.)
 - Pull out the main shaft. (See Fig.21.)
 - Remove the screw **M** attaching the pickup to the rack plate. (See Fig.22.)

Reference:

When attaching the loading motor, apply grease to the sections **s** and **t**. (See Fig.21.)

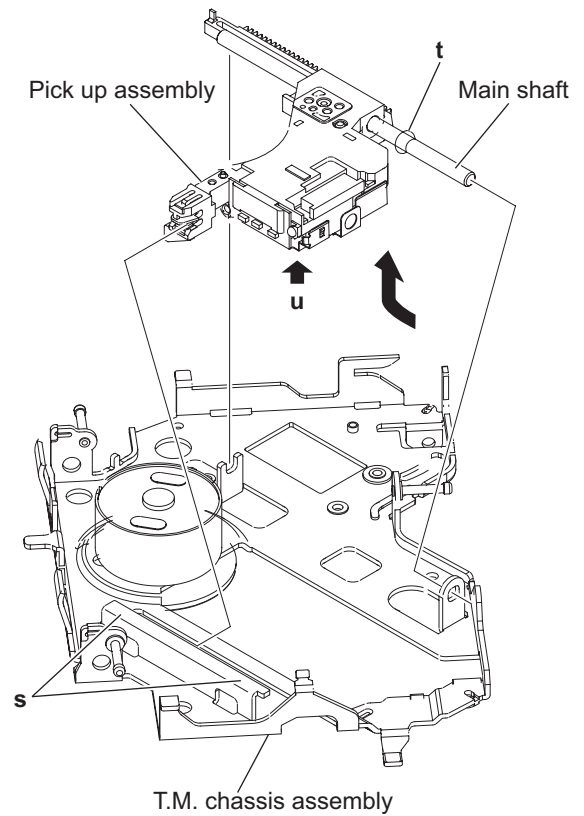

Fig.21

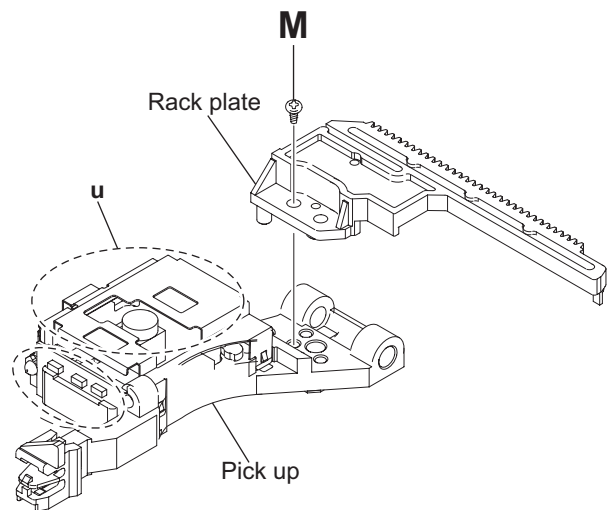

Fig.22

3.2.14 Removing the spindle motor (See Fig.23 and 24)

- Remove the MECHANISM CONTROL BOARD assembly, top cover, mechanism section, clamper assembly, feed motor assembly and pickup assembly.

- From the top side of the T.M chassis assembly, remove the CD T.table assembly from the spindle motor. (See Fig.23.)
- Remove the two screws **N** attaching the spindle motor. (See Fig.23.)
- Take out the spindle motor from the bottom side of the T.M chassis assembly. (See Fig.23.)

Reference:

When attaching the CD T.table assembly to the spindle motor shaft, apply loctite 460 to inside the CD T.table assembly. (See Fig.24.)

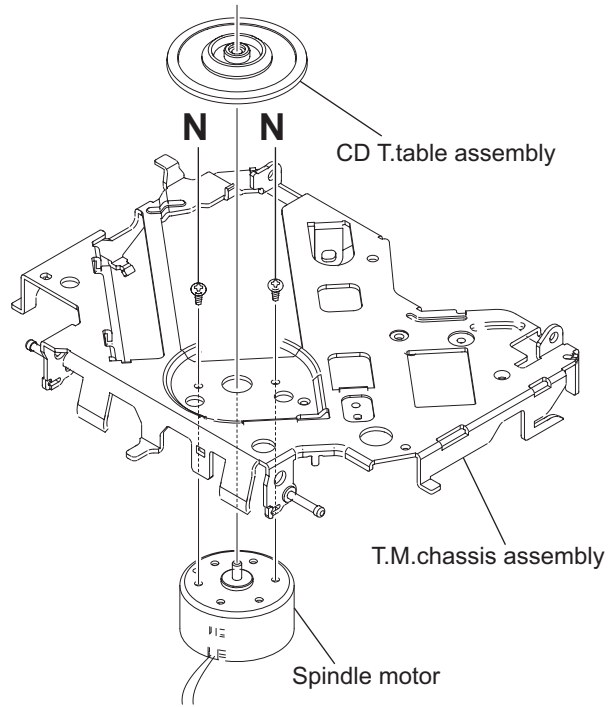

Fig.23

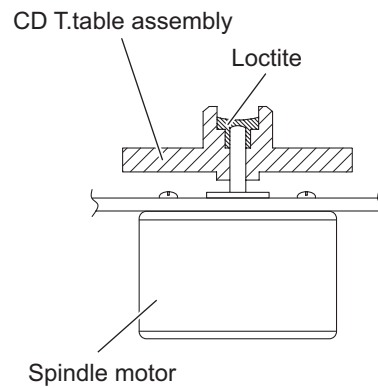

Fig.24

SECTION 4 ADJUSTMENT

4.1 Test instruments required for adjustment

- (1) Digital oscilloscope (100MHz)
- (2) Digital tester
- (3) Test Disc
- (4) Extension cable : EXTGS004-26PL

4.2 Standard measuring conditions

Power supply voltage DC14.4V(10.5 to 16V)
Load impedance 20K ohm (2 Speakers connection)
Output Level Line out 2.5V (Vol. MAX)

4.5 How to connect the extension cable for adjusting

Caution:

Be sure to attach the heat sink and rear bracket onto the power amplifier IC and regulator IC respectively, before supply the power. If voltage is applied without attaching these parts, the power amplifier IC and regulator IC will be destroyed by heat.

4.3 Standard volume position

Balance and Bass & Treble volume : Indication "0"
Loudness : OFF

4.4 Dummy load

Exclusive dummy load should be used for AM, and FM.
For FM dummy load, there is a loss of 6dB between SSG output and antenna input.
The loss of 6dB need not be considered since direct reading of figures are applied in this working standard.

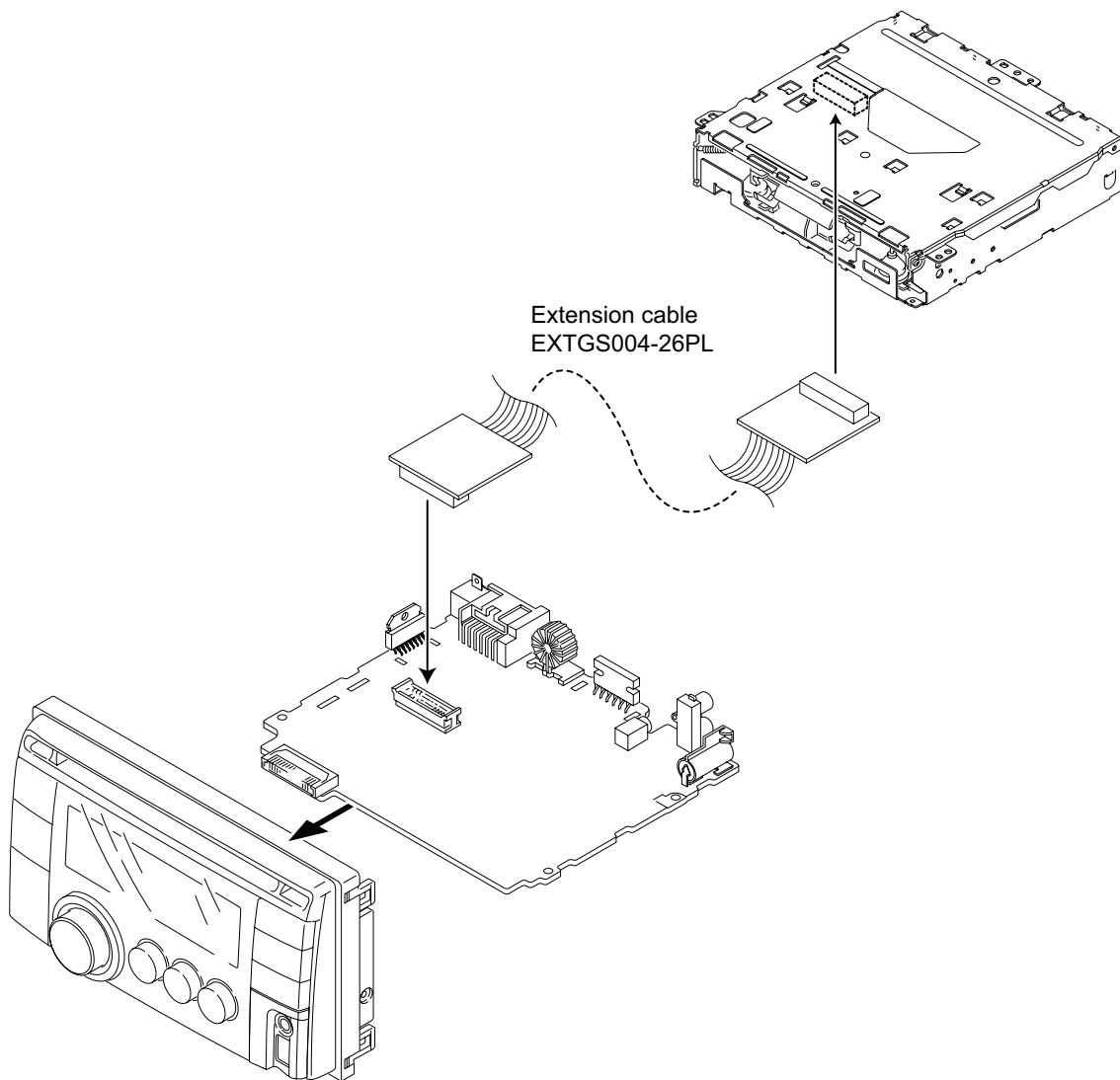

4.6 Service Mode

4.6.1 Service mode setting

- (1) Push POWER BUTTON (Power ON)
- (2) Set to service mode
Keep this state more 3 seconds while connecting pressing the [MENU] button and [▼] button sequentially.
- (3) Select the menu with [VOL -] and [VOL+], and decide it with [Enter] button.
- (4) When the [BACK] button is pushed, it returns to the former menu.

Service mode (MENU)

```
Service mode
Data Clear
Tuner Service Mode
CD Service mode
Bluetooth Version
HD Service Mode
Rom correction Mode
```

Service mode Version

```
MAIN **** Panel V*** MAIN: Main micon version Panel: Panel micon version
HD V*** USB V*** HD : HD radio version USB : USB micon version
CH V*** R **.* CH : CH version R : Panel micon ROM version
```

Error Read

OK: Function

```
CD Error Read
USB Error Read
CH Error Read
```

```
Total Error :****
E1 ***** E3 *****
E2 *****
1 ***** 4 *****
2 ***** 5 *****
3 *****
```

CD Data Read

OK: Function

```
ADJ NOW
ADJ INT
OTHERS
```

Data Clear

```
Initialize All
Name Clear
CD Error Clear
USB Error Clear
CH Error Clear
Init Bluetooth
Init HD Radio
```

```
FEB *** FEO*** TEB*** ADJ NOW
FGA *** TEO*** TGA*** ADJ INT
RFG ***
```

```
IOP TEMP I**T OTHERS
TEMP MAX*** IOP INT**
P TOTAL ****H
```

Tuner Service Mode

```
VER=**** #####
TINJ=**
*** #####
#####
SPI=####
PI =#### PTY=##
TP =#TA=* MS =#DI=*
AF=#### **** $$$
LEV=###H U&W=###H
IFC=###H IFBW=#
RFAGC=## IFAGC=##
```

RDS Engineer Mode

VOL PUSH: Enter

```
TUR=## - - **
TUV=## - - **
F/A-LEV=*****
F/A-USN=*****
F/A-WAM=*****
F/A-IFC=*****
F-LV1=*****
IF-BW=*****
SKTM=*****
RDTM=*****
*** #####
#####
```

CD Service Mode

```
FEBC =**
TEBC =**
FEOF =** FGADD=**
RFGC=** TGADD=**
JPTRM=** TEOF =**
RFRP=** SPOFF=**
TEPK=** JPTRL=**
DMO=** TRLPF=**
```

Bluetooth Version

```
SW_BT_CORE ***
HW_BT_MODULE ***
SW_BT_MODULE ***
ADR=*****
```

HD Service Mode

(It is displayed in HD Radio Tuner connection.)

```
SM **
IDM V***
MP **
ADJ **
IFBW *
IF *****
QI **
SNR **
BCNT *
AGAIN **
SPROC **
```

Rom correction Mode : Rom corre version

4.6.2 Mechanical Error Detail Codes

Condition	Details	Error Code	Detail Code
Disc Loading Error			
(1) B1 Time Out	After detecting SW1=L, it does not become SW2=L	09	0011
(2) B2 Time Out	After detecting SW2=H, it does not become SW2=L	09	0012
(3) C1 Time Out	After detecting SW2=L, it does not become SW2=H	09	0013
Eject Error			
(1) B1 Time Out	After detecting SW2=H, it does not become SW2=L	01	0021
(2) C2 Time Out	After detecting SW2=L, it does not become SW2=H	01	0022
(3) B2 Time Out	After detecting SW1=L, it does not become SW2=L immediately after RESET and so on.	01	0023
(4) D0 Panel Close	Disc can not be ejected due to closed panel.	01	0024
Forced Eject Error			
(1) E1 Error	SW1=H, SW2=L detected from NO DISC	01	0041
(2) E2 Error	Detected SW1=L after RESET, and then detected SW1=H	01	0042
(3) E3 Error	Detected SW1=H after RESET	01	0043
(4) E4 Error	Detected SW1=H after SW1=L	01	0044
(5) E5 Error	Detected SW1=H after SW2=H→L	01	0045
(6) E6 Error	Time Out for Loading after RESET	01	0046
(7) E7 Error	Detected SW1=H after SW2=H→L→H	01	0047
(8) E8 Error	Eject Key input while the procedure is not completed after	01	0048
	Forced Eject execution		
(9) E9 Error	Eject Key input during Disc is on the way and not completed	01	0049
Loading Waiting Error			
(1) SW1=H or NO DISC detection before Loading Motor activation during Disc is waiting at the waiting location.	Disc is removed or NO DISC detection condition	09	0031
(2) SW2=L before Loading Motor activation during Disc is waiting at the waiting location.	Disc is inserted	09	0032

SECTION 5 TROUBLESHOOTING

5.1 16 PIN CORD DIAGRAM (For KW-XR810)

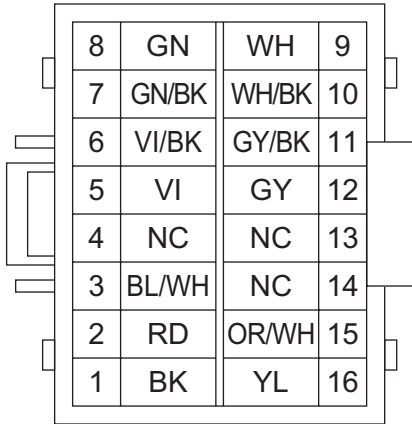

BK	Black	GN	Green
RD	Red	GY	Gray
BL	Blue	OR	Orange
WH	White	YL	Yellow
VI	Violet		

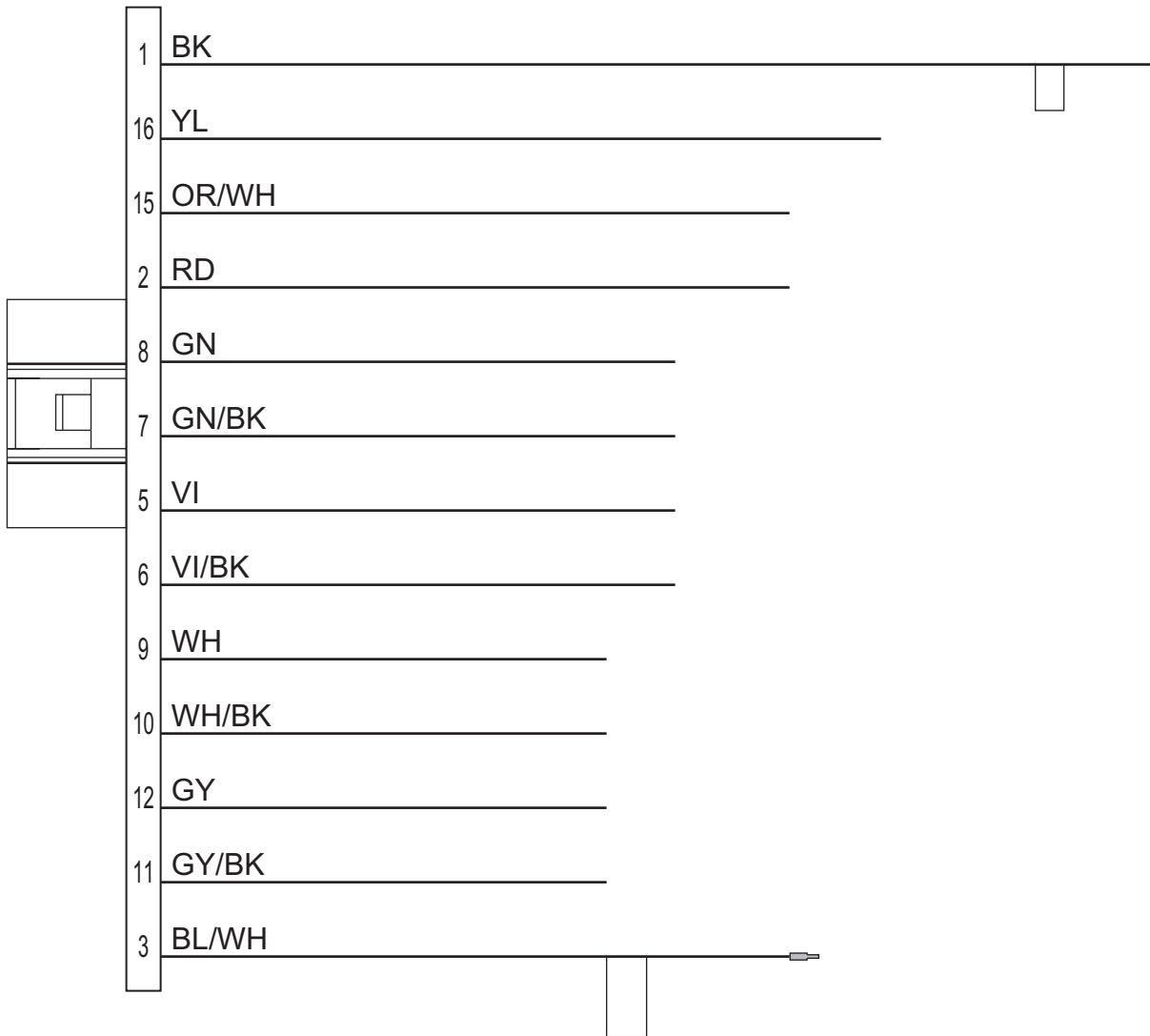

5.2 16 PIN CORD DIAGRAM (For KW-XR811, KW-XR817)

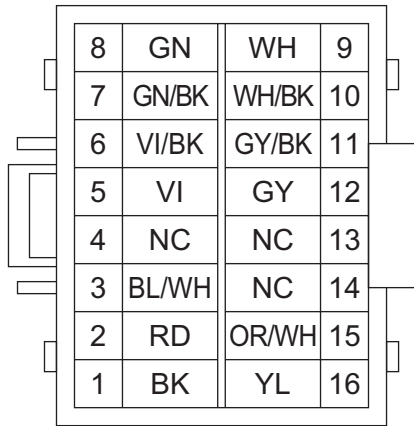

BK	Black	GN	Green
RD	Red	GY	Gray
BL	Blue	OR	Orange
WH	White	YL	Yellow
VI	Violet		

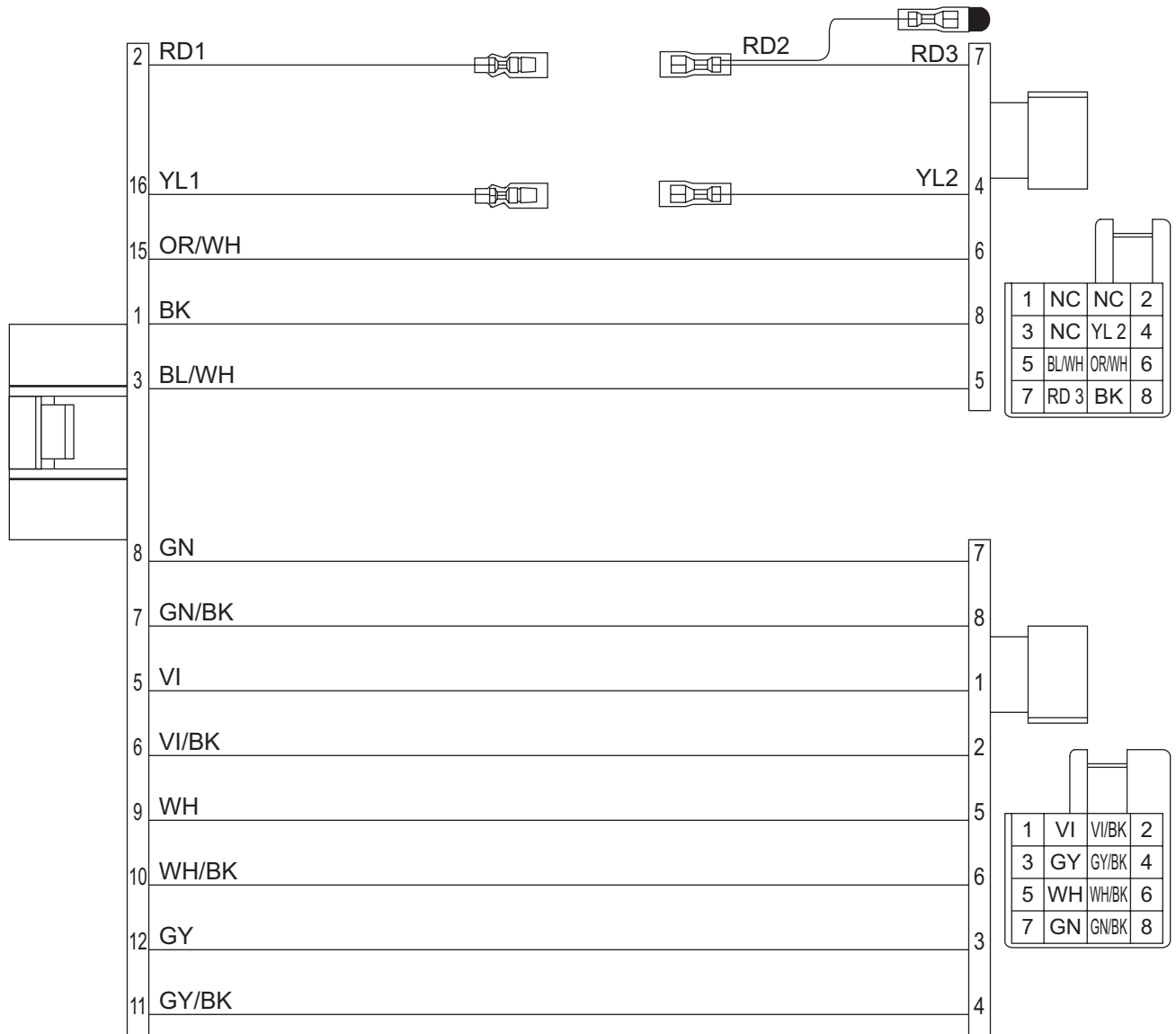

5.3 16 PIN CORD DIAGRAM (For KW-XR611)

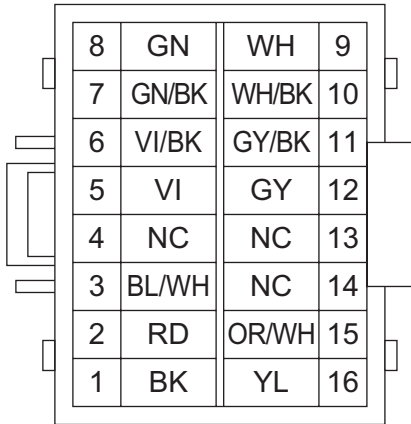

BK	Black	GN	Green
RD	Red	GY	Gray
BL	Blue	OR	Orange
WH	White	YL	Yellow
VI	Violet		

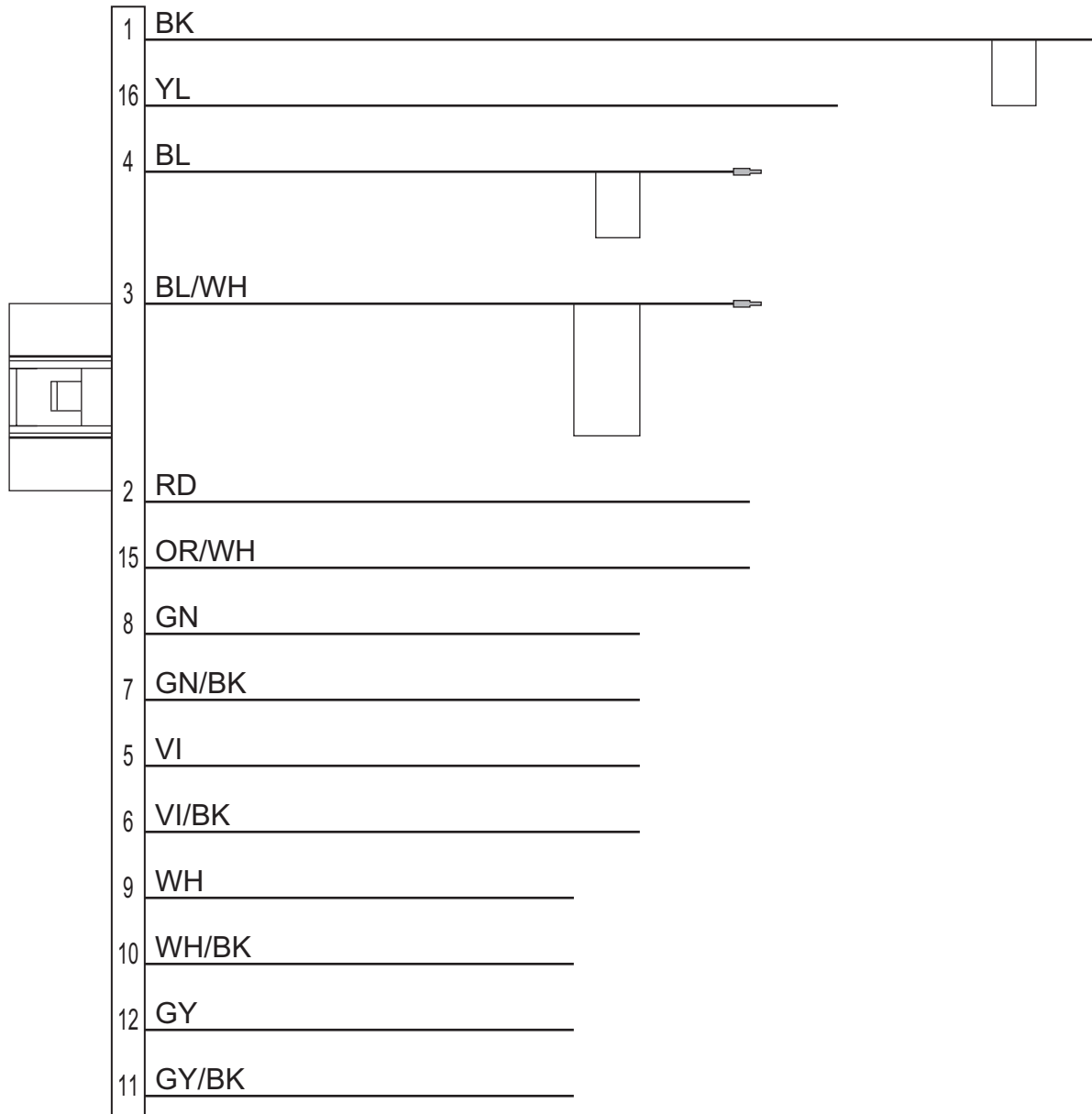



JVC

Victor Company of Japan, Limited
Mobile Entertainment Division 10-1,1chome,Ohwatari-machi,Maebashi-city,371-8543,Japan

(No.MA475<Rev.001>)

Printed in Japan
VSE



SCHEMATIC DIAGRAMS

CD RECEIVER

KW-XR810J
KW-XR811E

KW-XR816U
KW-XR811EY
KW-XR817EE

KW-XR816UH
KW-XR811EU



■ PRECAUTIONS ON SCHEMATIC DIAGRAMS

- Due to the improvement in performance, some part numbers shown in the circuit diagrams may not agree with those indicated in the Parts List.
- The parts numbers, values and rated voltage etc. in the Schematic Diagrams are for reference only.
- Since the circuit diagrams are standard ones, the circuits and circuit constants may be subject to change for improvement without any notice.

■ PRECAUTIONS ON PARTS LIST

- The parts identified by the \triangle symbol are critical for safety. Whenever replacing these parts, be sure to use specified ones to secure the safety.
- The parts not indicated in this Parts List and those which are filled with lines --- in the Parts No. columns will not be supplied.
- P.W. BOARD Ass'y will not be supplied, but those which are filled with the Parts No. in the Parts No. columns will be supplied.
- When ordering chips, screws etc., place bulk orders (unit of tens) whenever possible to improve shipping efficiency.
- There are cases where the actual implemented parts in the sets and the service parts are different. When ordering parts, make sure to refer to the Parts List.

■ PRECAUTIONS ON SERVICE

Certain parts of the power circuits and the GNDs differ according to the models. Care must be taken for the following points as the differences are indicated separately in the LIVE GND () and the ISOLATED (NEUTRAL) GND (.

1. Do not touch the LIVE GND, or do not touch the LIVE GND and the ISOLATED (NEUTRAL) GND at the same time. It may cause an electric shock.
Before pulling out the chassis or other parts, make sure to pull out the power cord from the wall outlet first.
2. Do not short circuit between the LIVE GND and ISOLATED (NEUTRAL) GND, or never measure the LIVE GND and ISOLATED (NEUTRAL) GND at the same time using measuring instruments (oscilloscope, etc.). It may blow fuses or damage other parts.

■ DEVIATION TOLERANCE RANGE

DEVIATION TOLERANCE RANGE									
F	G	J	K	M	N	R	H	Z	P
± 1%	± 2%	± 5%	±10%	±20%	±30%	+30% -10%	+50% -10%	+80% -20%	+100% -0%

Block diagram

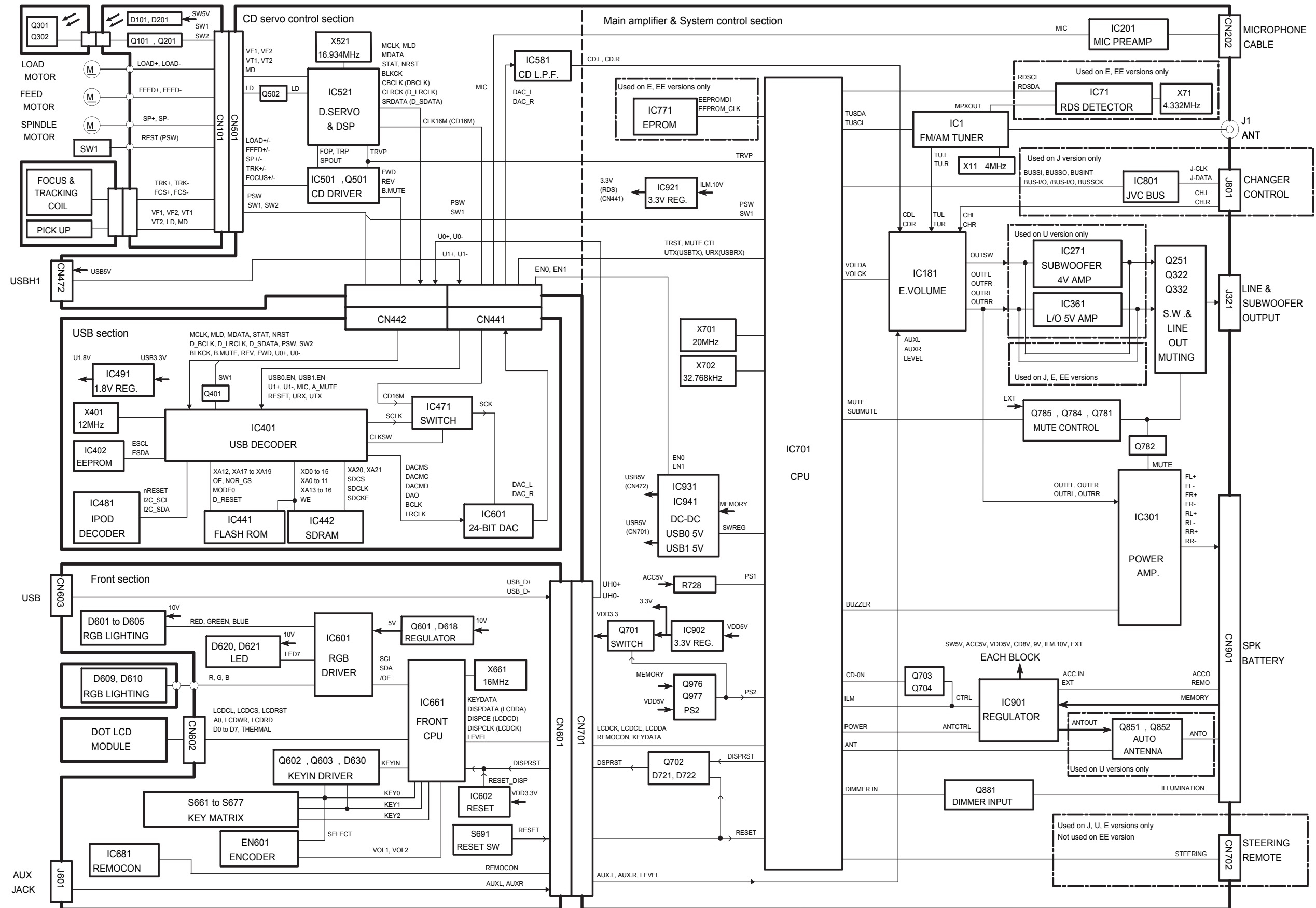

<Main section 1>

USE OF OTHER DIV : JEIN

NOTES

1. VOLTAGES ARE DC-MEASURED WITH A DIGITAL VOLT METER WITHOUT INPUT SIGNAL.
2. UNLESS OTHERWISE SPECIFIED, ALL RESISTORS ARE 1/16W 5% METAL GLAZE RESISTOR. ALL CAPACITORS ARE 50V OR 25V CERAMIC CAPACITOR. ALL RESISTANCE VALUES ARE IN OHM. ALL CAPACITANCE VALUES ARE IN (P#F). ALL E-CAPACITORS ARE SHOWN IN THE FORM OF CAPACITANCE (μF/RATED VOLTAGE).
3. COMPONENTS IN () INDICATE NOT USE.

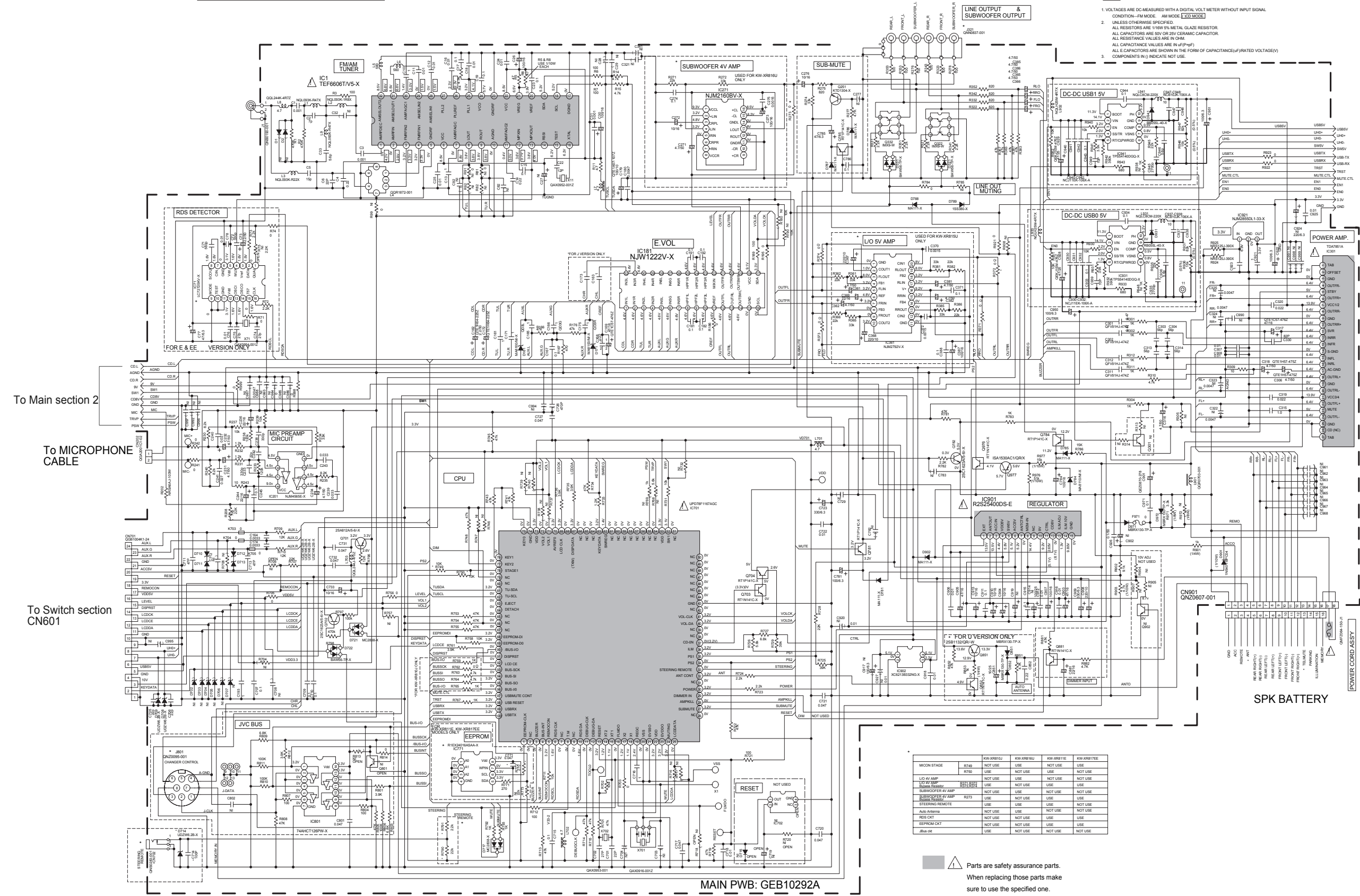

	R740	R749	R750	R751	R752
MOON STAGE	NOT USE	USE	USE	NOT USE	USE
LID 4V AMP	NOT USE	USE	NOT USE	USE	NOT USE
VOL 5V AMP	USE	NOT USE	USE	NOT USE	USE
SUBWOOFER 4V AMP	NOT USE	USE	NOT USE	USE	NOT USE
SUBWOOFER 4V AMP	NOT USE	USE	NOT USE	USE	NOT USE
STEREO REMOTE	USE	USE	USE	NOT USE	USE
ANTENNA	NOT USE	USE	NOT USE	USE	NOT USE
RDS CKT	NOT USE	NOT USE	USE	USE	USE
EEPROM CKT	NOT USE	NOT USE	USE	USE	USE
JBus SW	USE	NOT USE	NOT USE	NOT USE	NOT USE

Parts are safety assurance parts.
When replacing those parts make
sure to use the specified one.

MAIN PWB: GEB10292A

To Main section 2

To MICROPHONE CABLE

To Switch section CN601

<Main section 2>

USE OF OTHER DIV : JEIN

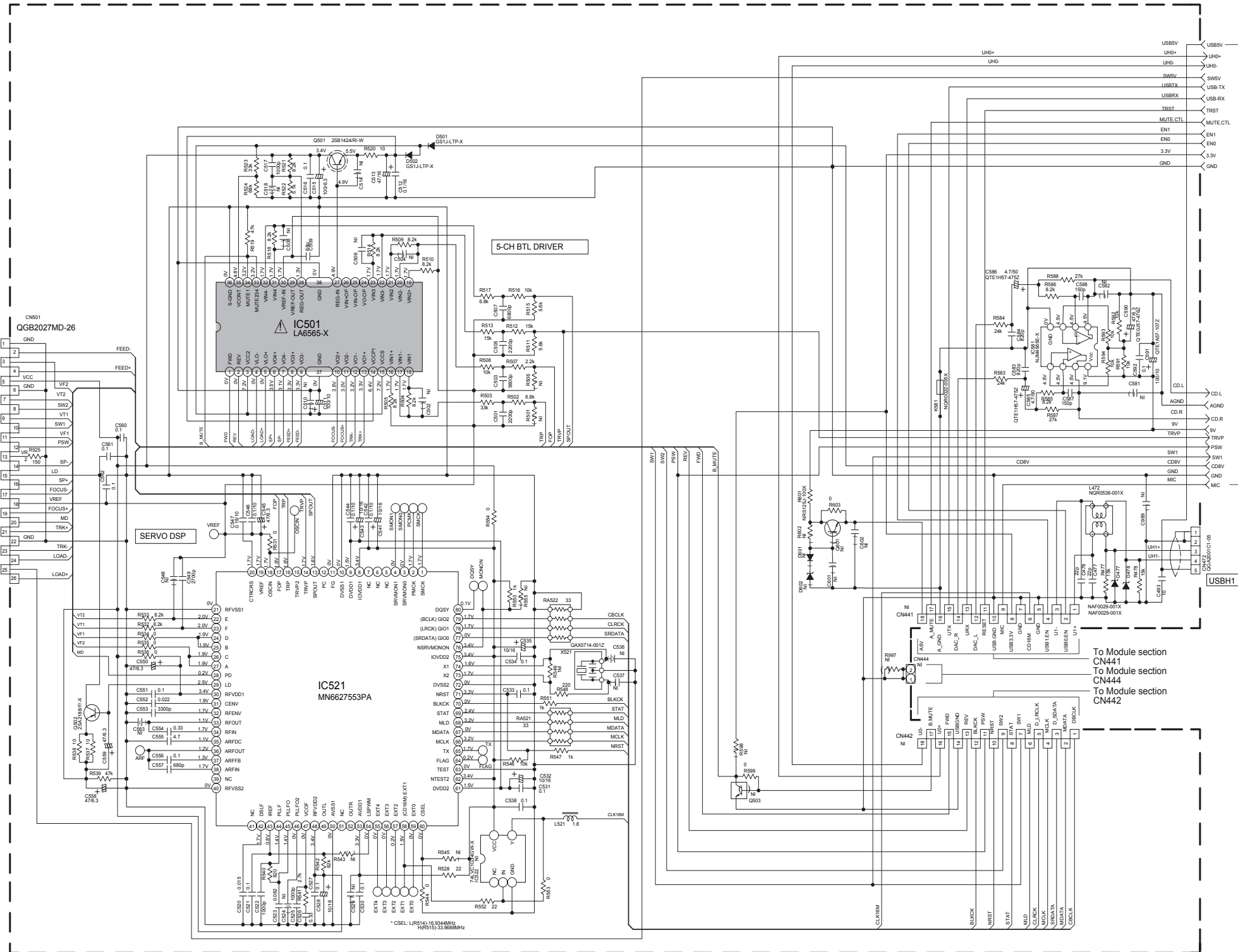

MAIN PWB: GEB10292A

 Parts are safety assurance parts.
When replacing those parts make
sure to use the specified one.

- NOTES
1. VOLTAGES ARE DC-MEASURED WITH A DIGITAL VOLT METER WITHOUT INPUT SIGNAL.
CONDITION—FM MODE AM MODE (VCD MODE)
 2. UNLESS OTHERWISE SPECIFIED.
ALL RESISTORS ARE 1/16W 5% METAL GLAZE RESISTOR.
ALL CAPACITORS ARE 50V OR 25V CERAMIC CAPACITOR.
ALL RESISTANCE VALUES ARE IN OHM.
ALL CAPACITANCE VALUES ARE IN uF(pF)
 3. ALL E-CAPACITORS ARE SHOWN IN THE FORM OF CAPACITANCE(uF)RATED VOLTAGE(V)
COMPONENTS IN () INDICATE NOT USE.

To Mecha control section
CN101

To Main section 1

To Module section
CN441
To Module section
CN444
To Module section
CN442

<Switch section>

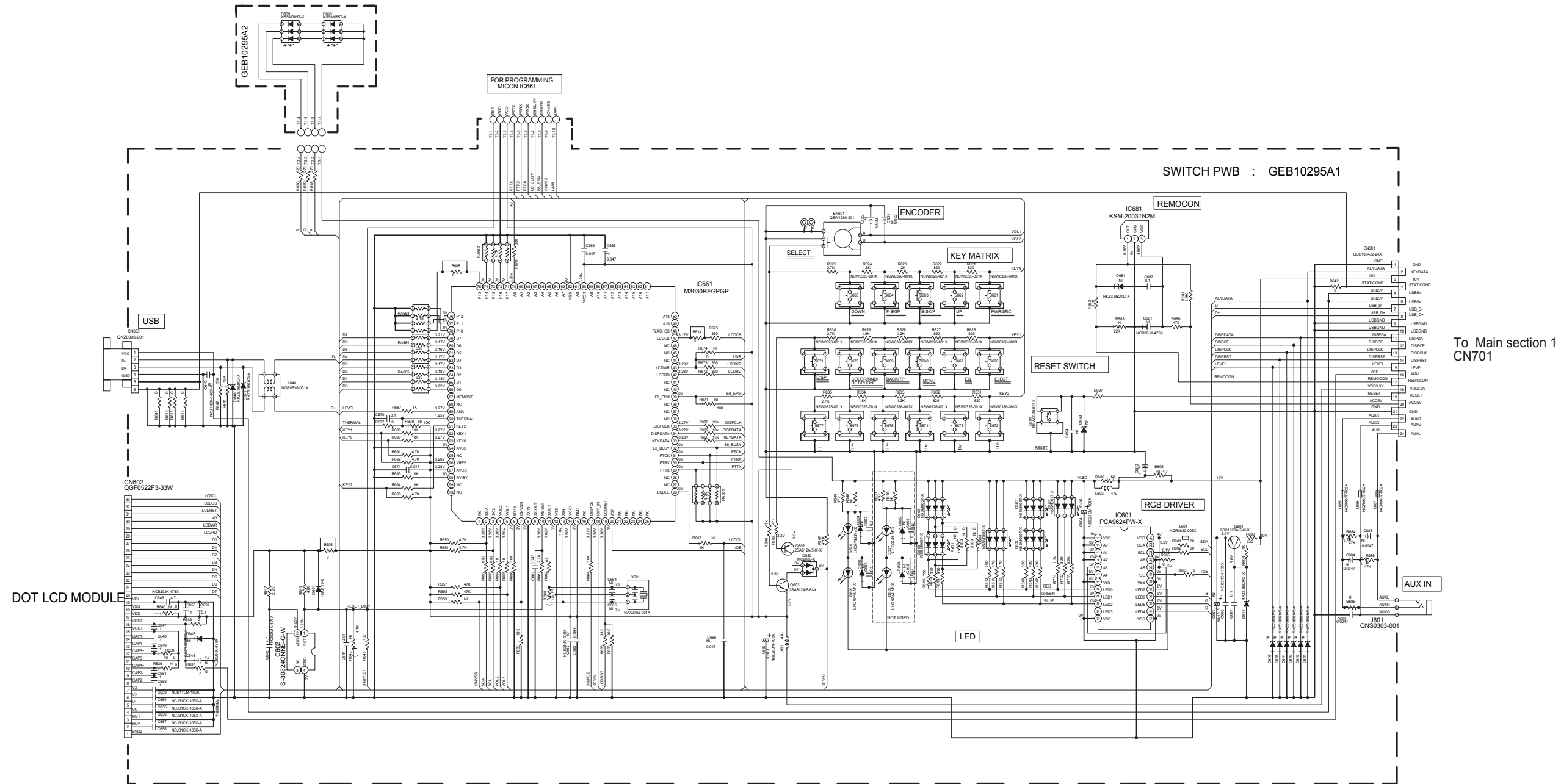

DOT LCD MODULE

To Main section 1 CN701

<Module section>

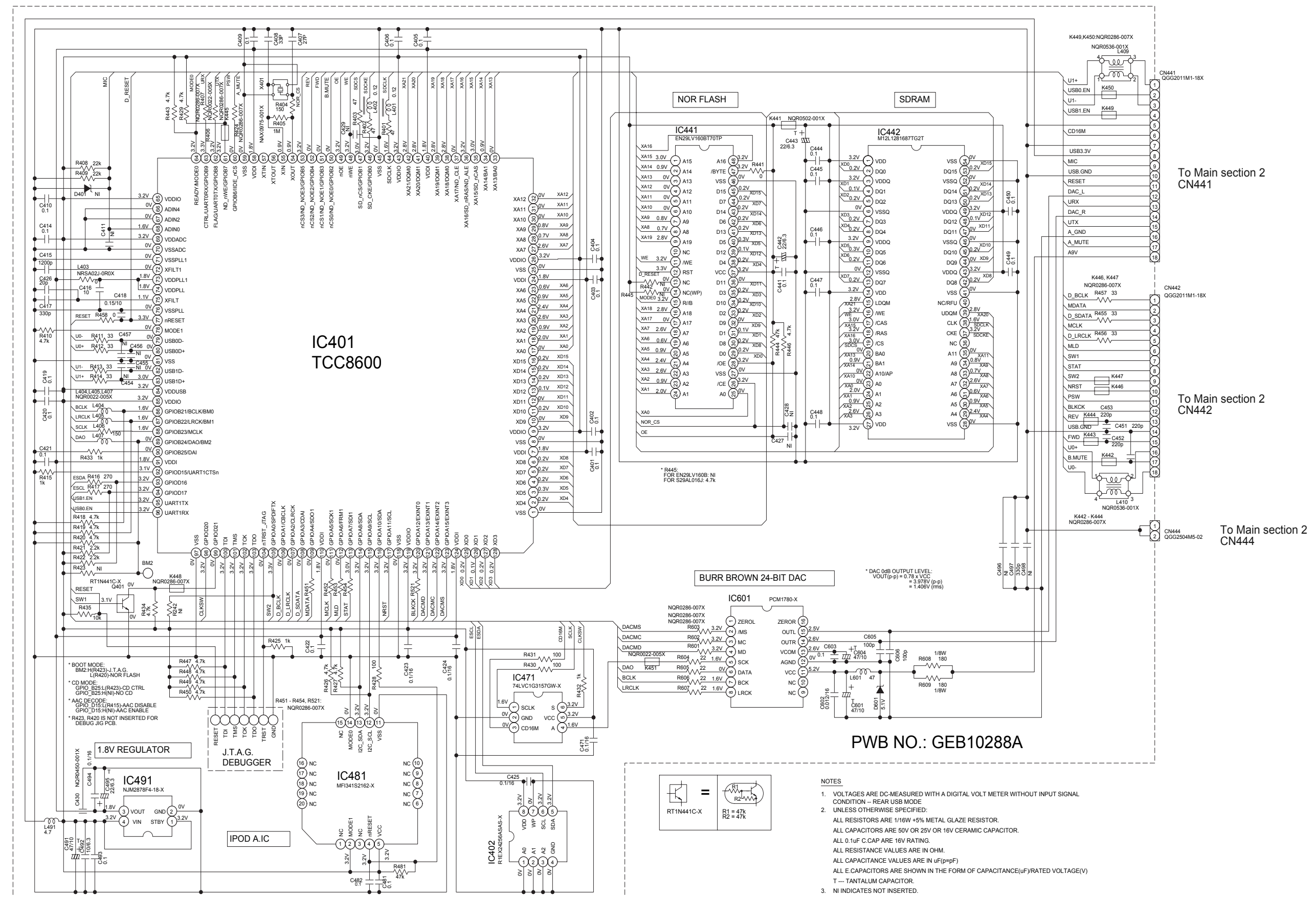

To Main section 2
CN441

To Main section 2
CN442

To Main section 2
CN444

PWB NO.: GEB10288A

- NOTES
- VOLTAGES ARE DC-MEASURED WITH A DIGITAL VOLT METER WITHOUT INPUT SIGNAL CONDITION - REAR USB MODE
 - UNLESS OTHERWISE SPECIFIED:
ALL RESISTORS ARE 1/16W +5% METAL GLAZE RESISTOR.
ALL CAPACITORS ARE 50V OR 25V OR 16V CERAMIC CAPACITOR.
ALL 0.1uF C.CAP ARE 16V RATING.
ALL RESISTANCE VALUES ARE IN OHM.
ALL CAPACITANCE VALUES ARE IN uF(p=pF)
 - T --- TANTALUM CAPACITOR.
 - NI INDICATES NOT INSERTED.

<Mecha control section>

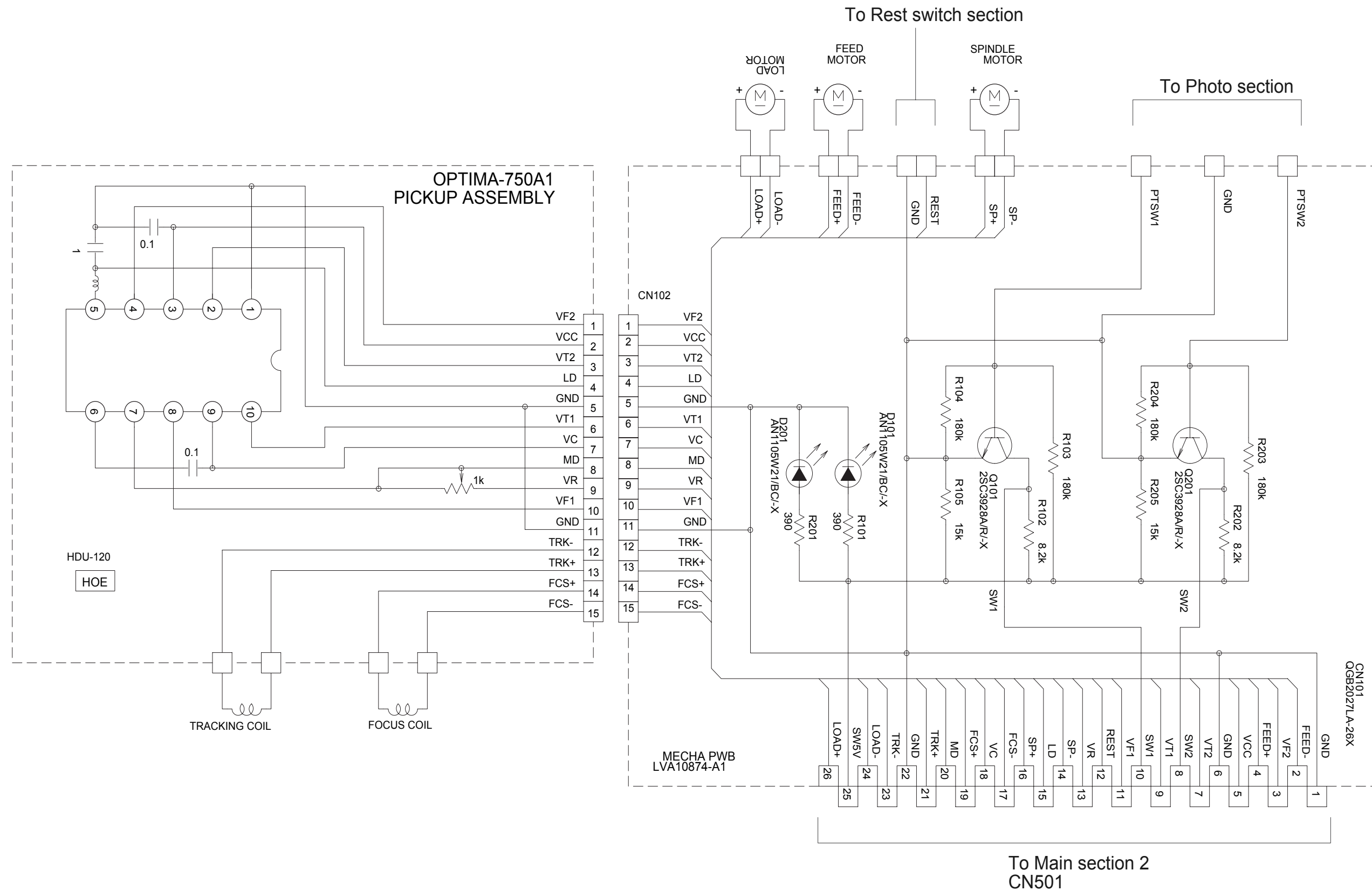

<Photo section>

PHOTO TR.PWB
LVA10874-A2

Q302

PS1191RB22/BC/X

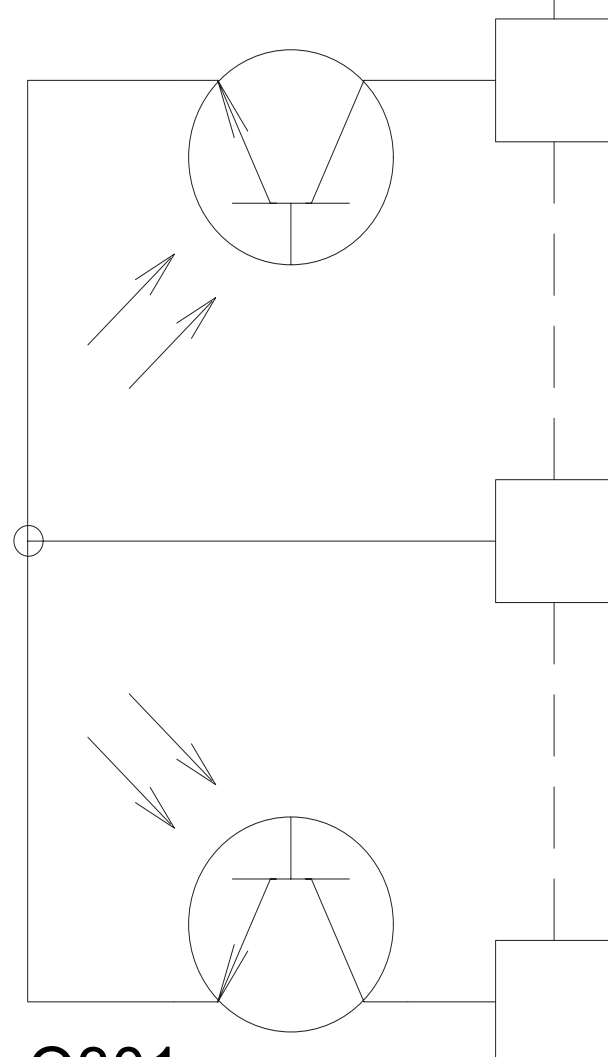

Q301

PS1191RB22/BC/X

To Mecha control section

<Rest switch section>

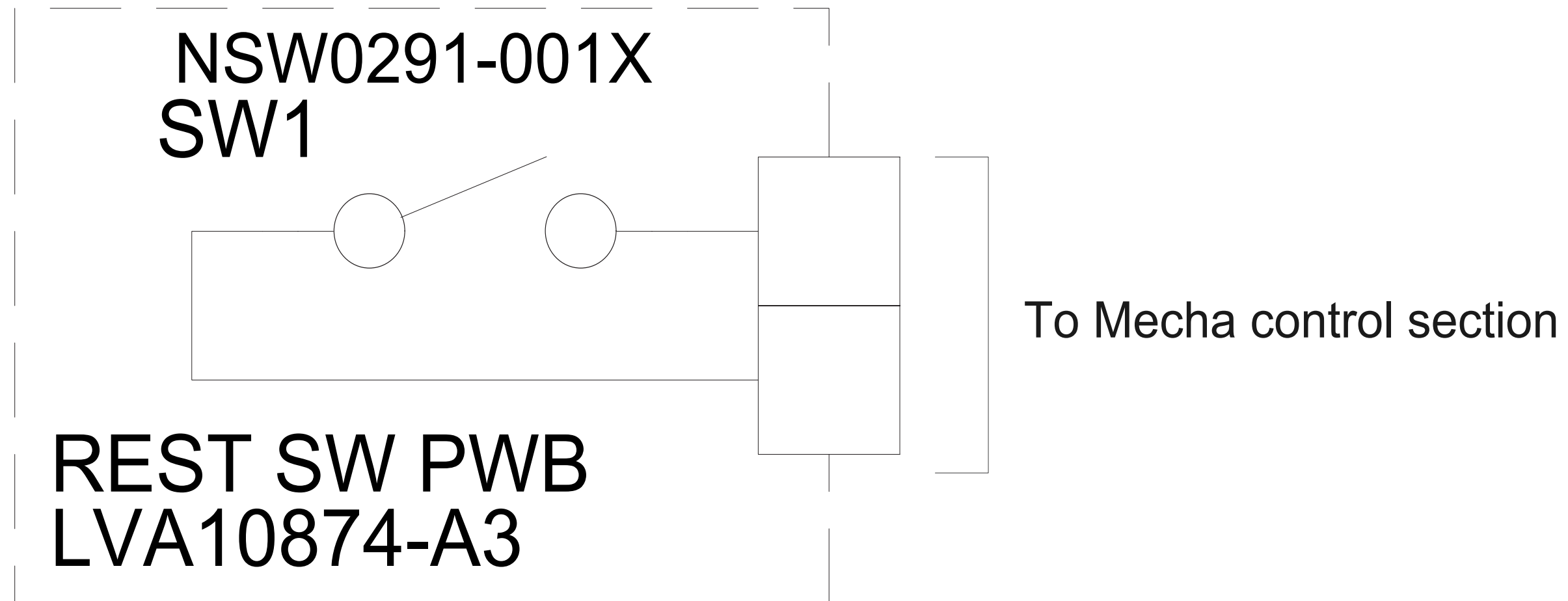

<Main board>

(Lead free solder used in the board (material : Sn-Ag-Cu, melting point : 219 Centigrade))
(Lead free solder used in the board (material : Sn-Cu, melting point : 230 Centigrade))

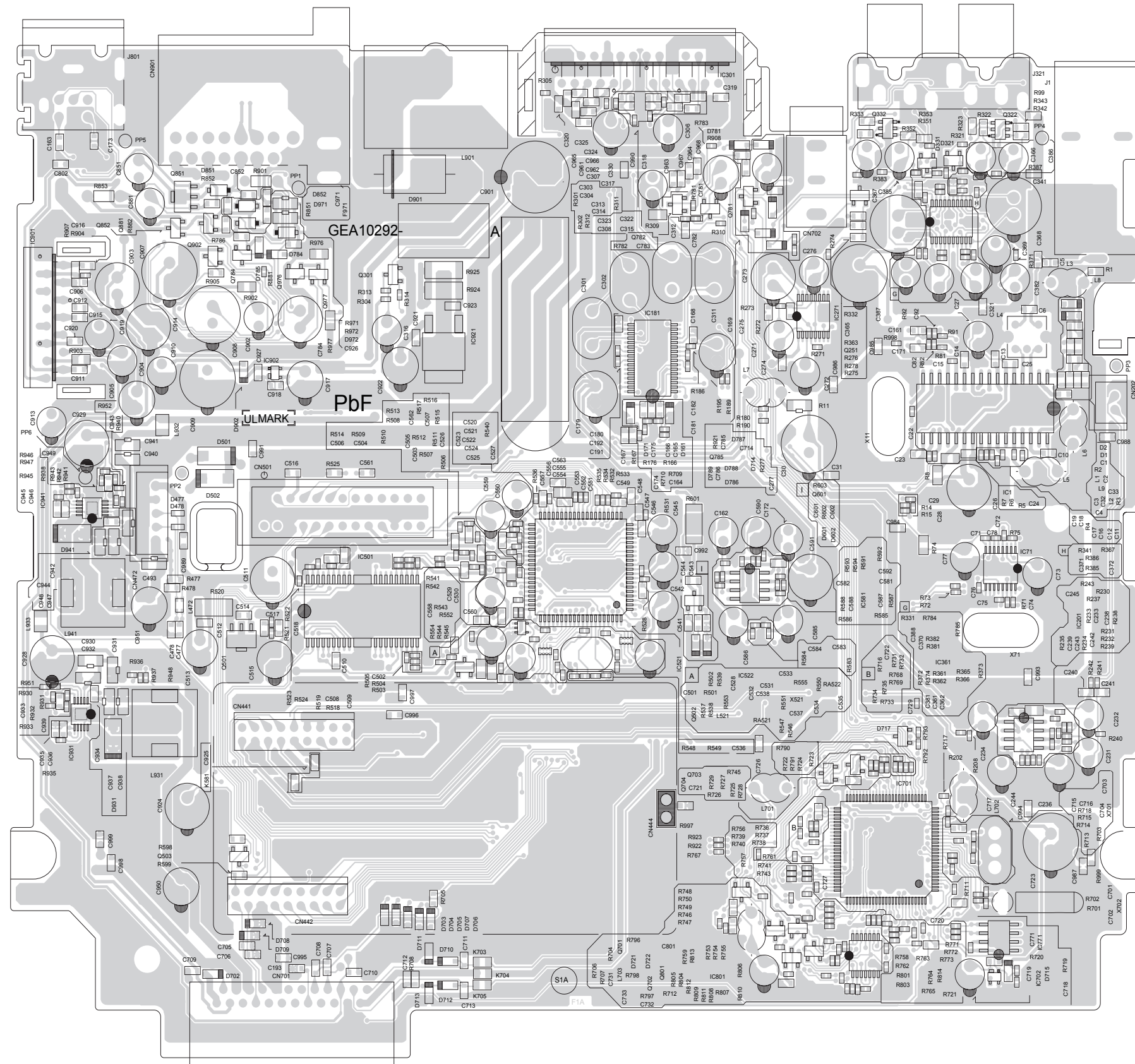

<Main board>

(Lead free solder used in the board (material : Sn-Ag-Cu, melting point : 219 Centigrade))
(Lead free solder used in the board (material : Sn-Cu, melting point : 230 Centigrade))

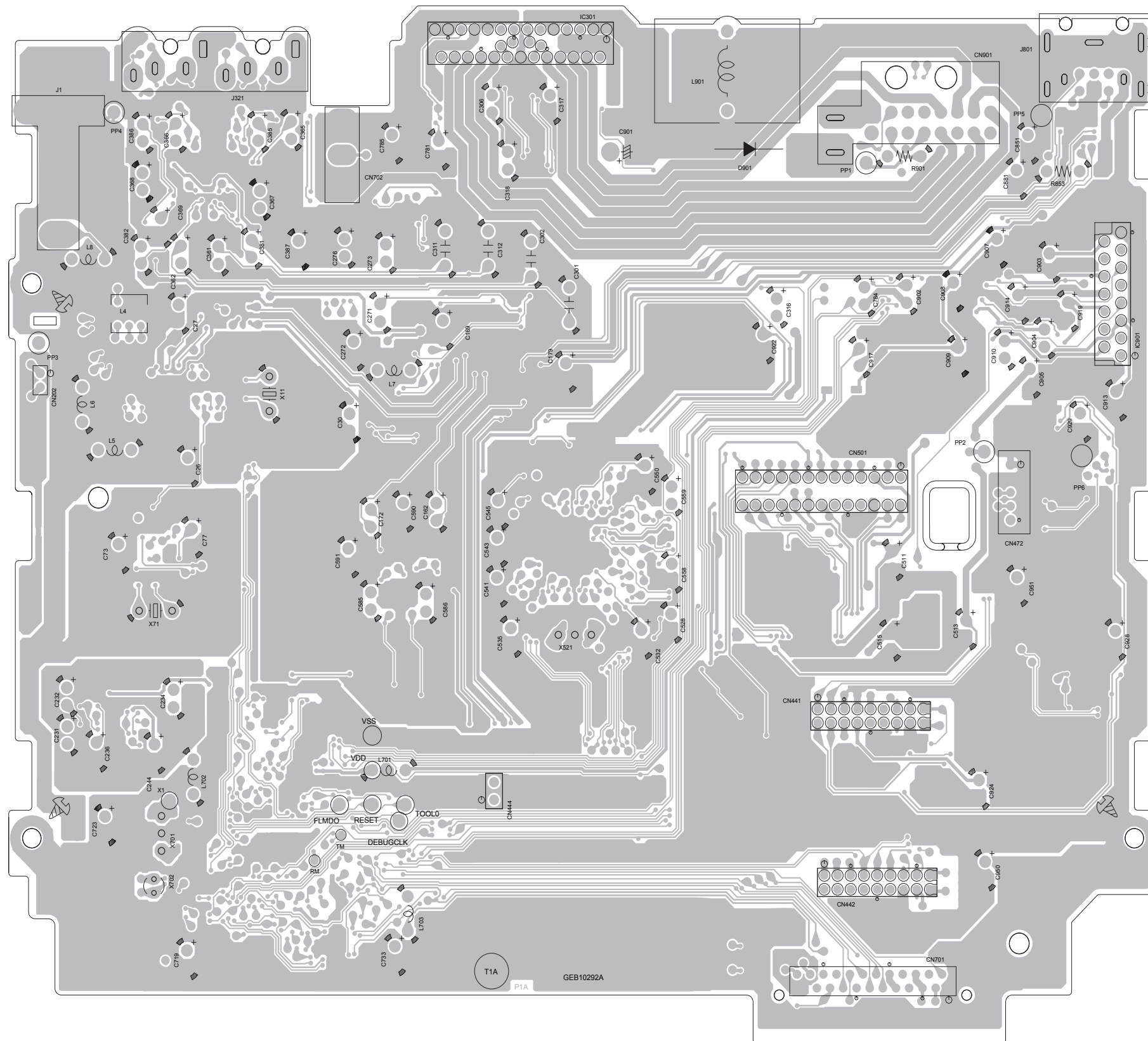

<Switch board>

(Lead free solder used in the board (material : Sn-Ag-Cu, melting point : 219 Centigrade))
(Lead free solder used in the board (material : Sn-Cu, melting point : 230 Centigrade))

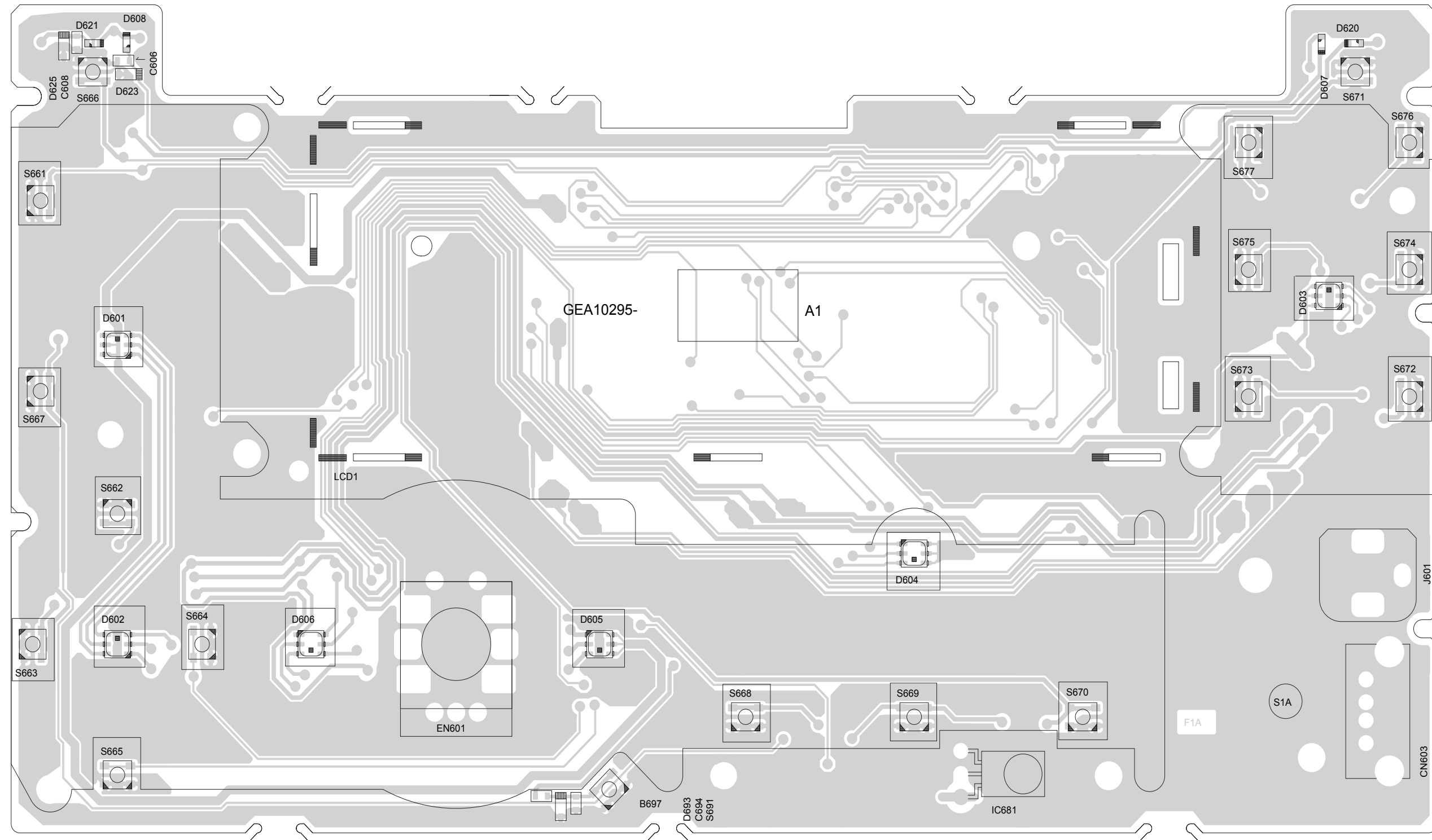

<Switch board>

(Lead free solder used in the board (material : Sn-Ag-Cu, melting point : 219 Centigrade))

(Lead free solder used in the board (material : Sn-Cu, melting point : 230 Centigrade))

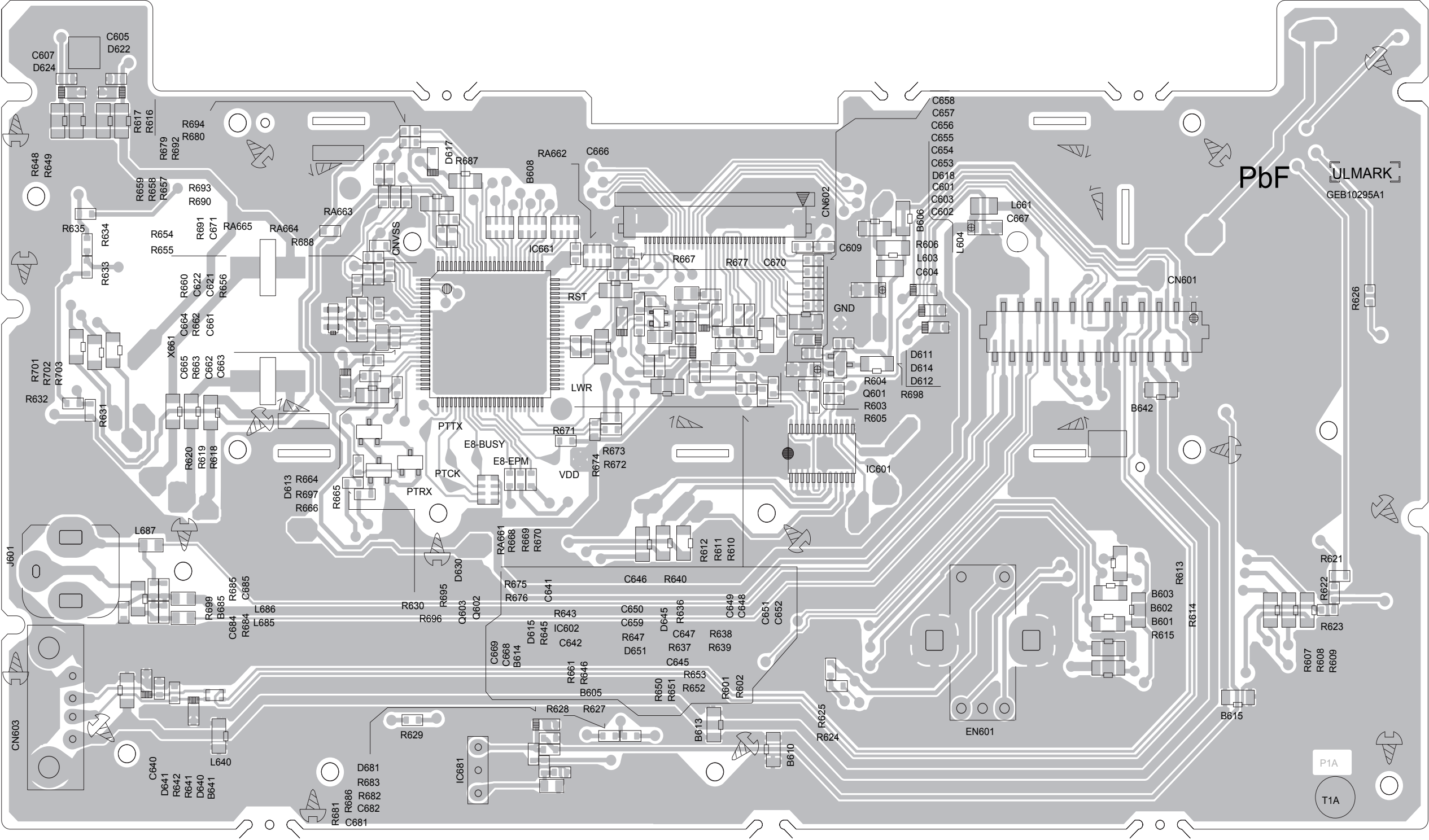

<LED board>

(Lead free solder used in the board (material : Sn-Ag-Cu, melting point : 219 Centigrade))
(Lead free solder used in the board (material : Sn-Cu, melting point : 230 Centigrade))

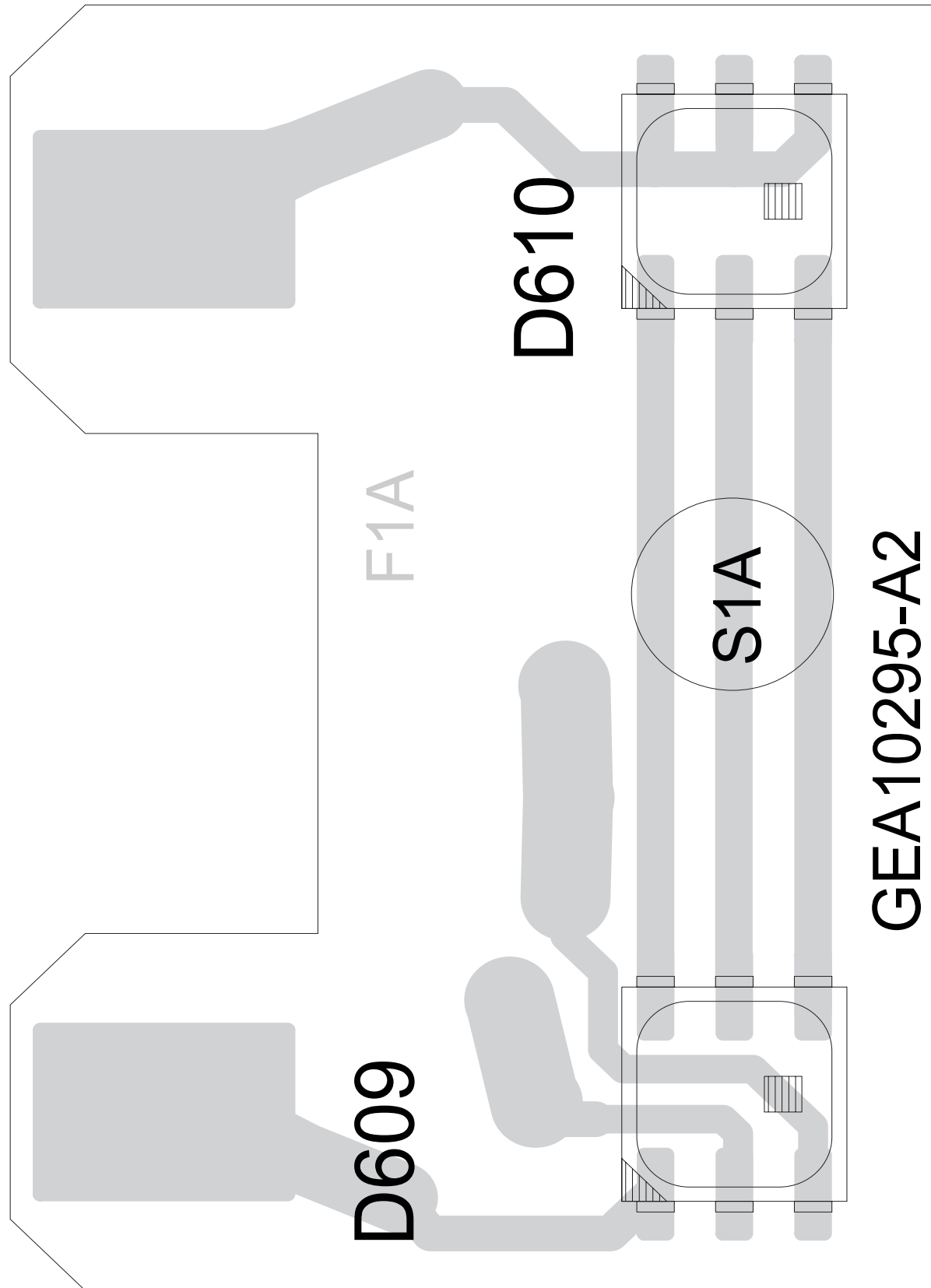

<LED board>

(Lead free solder used in the board (material : Sn-Ag-Cu, melting point : 219 Centigrade))

(Lead free solder used in the board (material : Sn-Cu, melting point : 230 Centigrade))

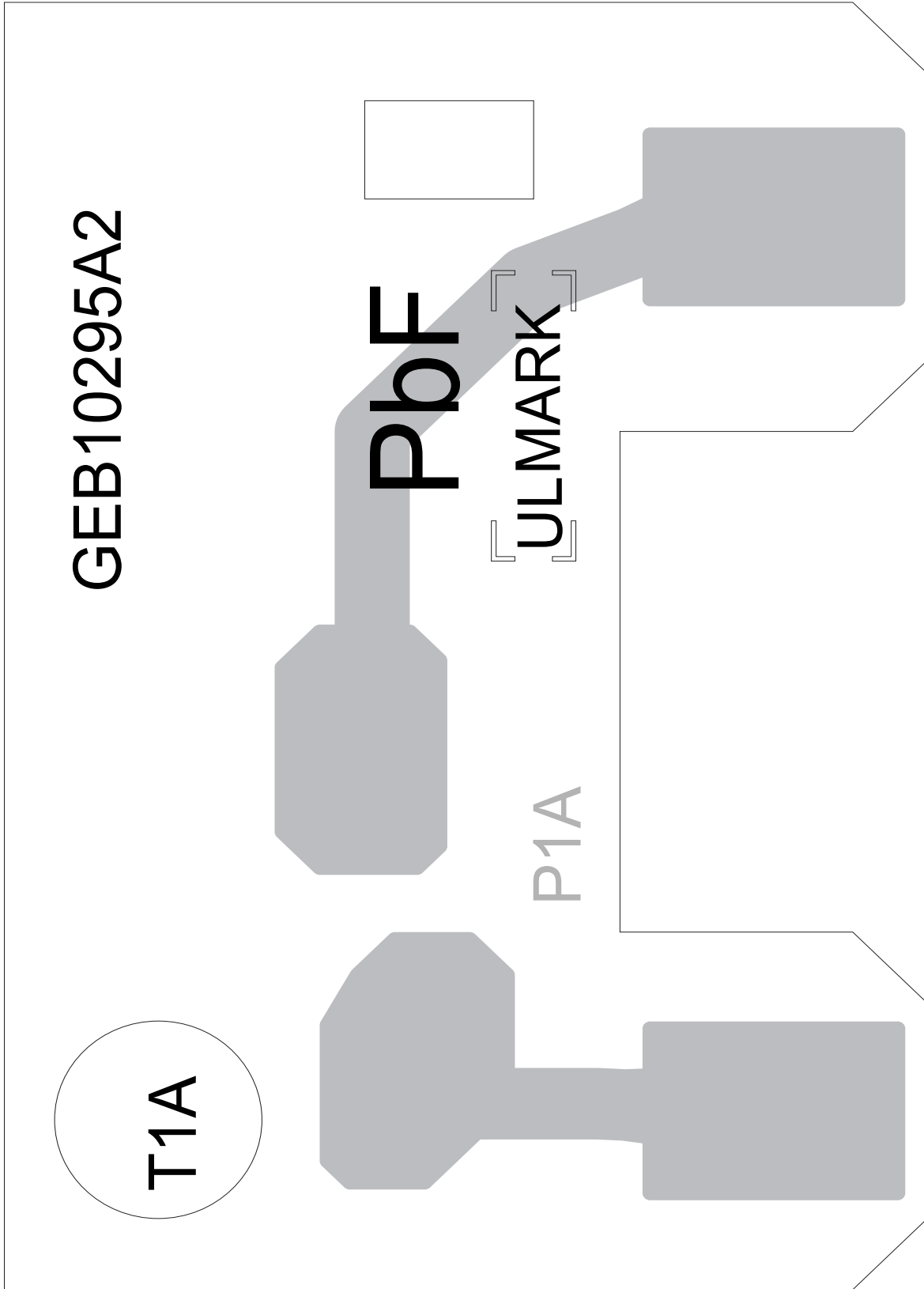

<Module board>

(Lead free solder used in the board (material : Sn-Ag-Cu, melting point : 219 Centigrade))
(Lead free solder used in the board (material : Sn-Cu, melting point : 230 Centigrade))

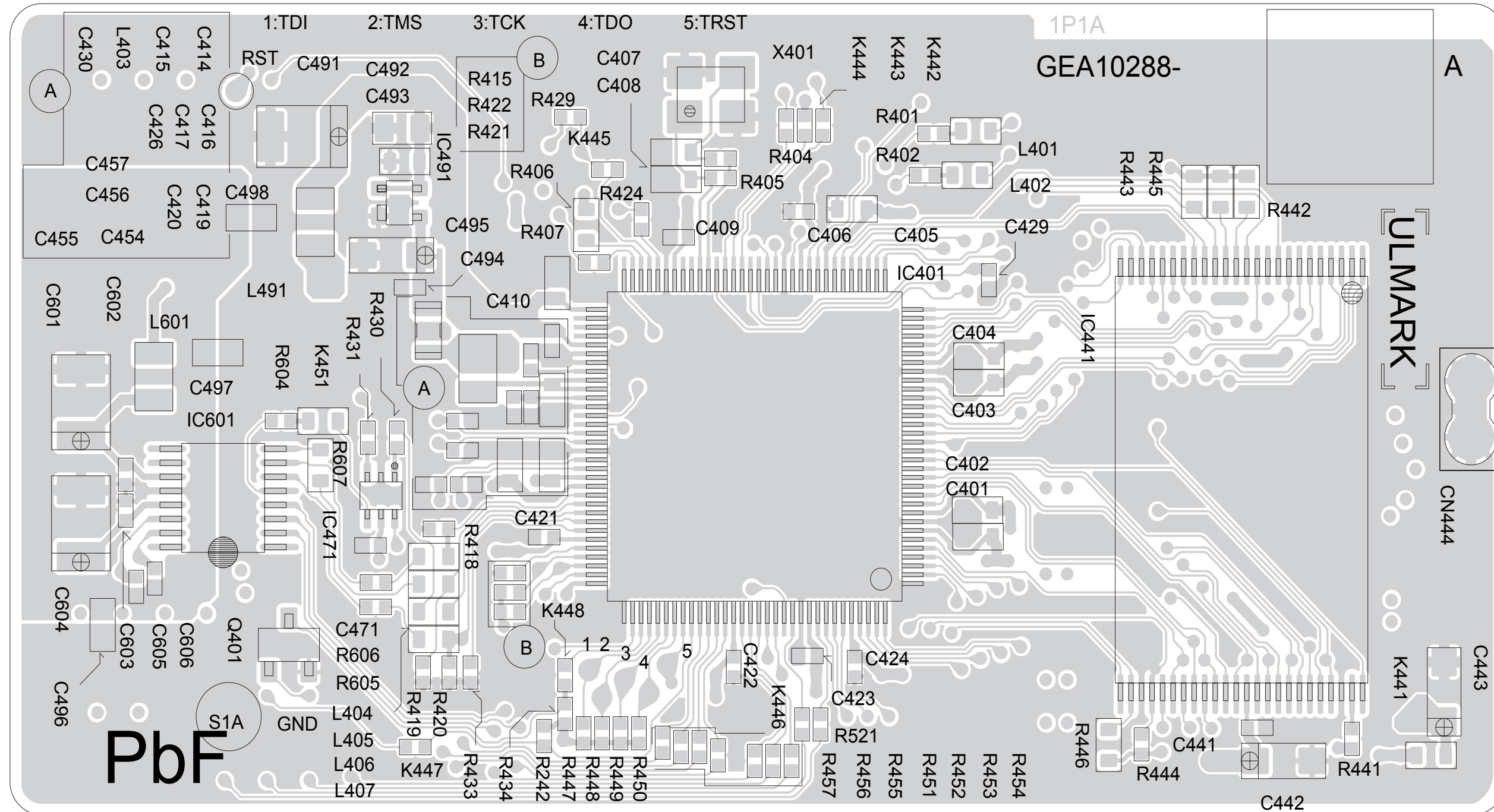

<Module board>

(Lead free solder used in the board (material : Sn-Ag-Cu, melting point : 219 Centigrade))

(Lead free solder used in the board (material : Sn-Cu, melting point : 230 Centigrade))

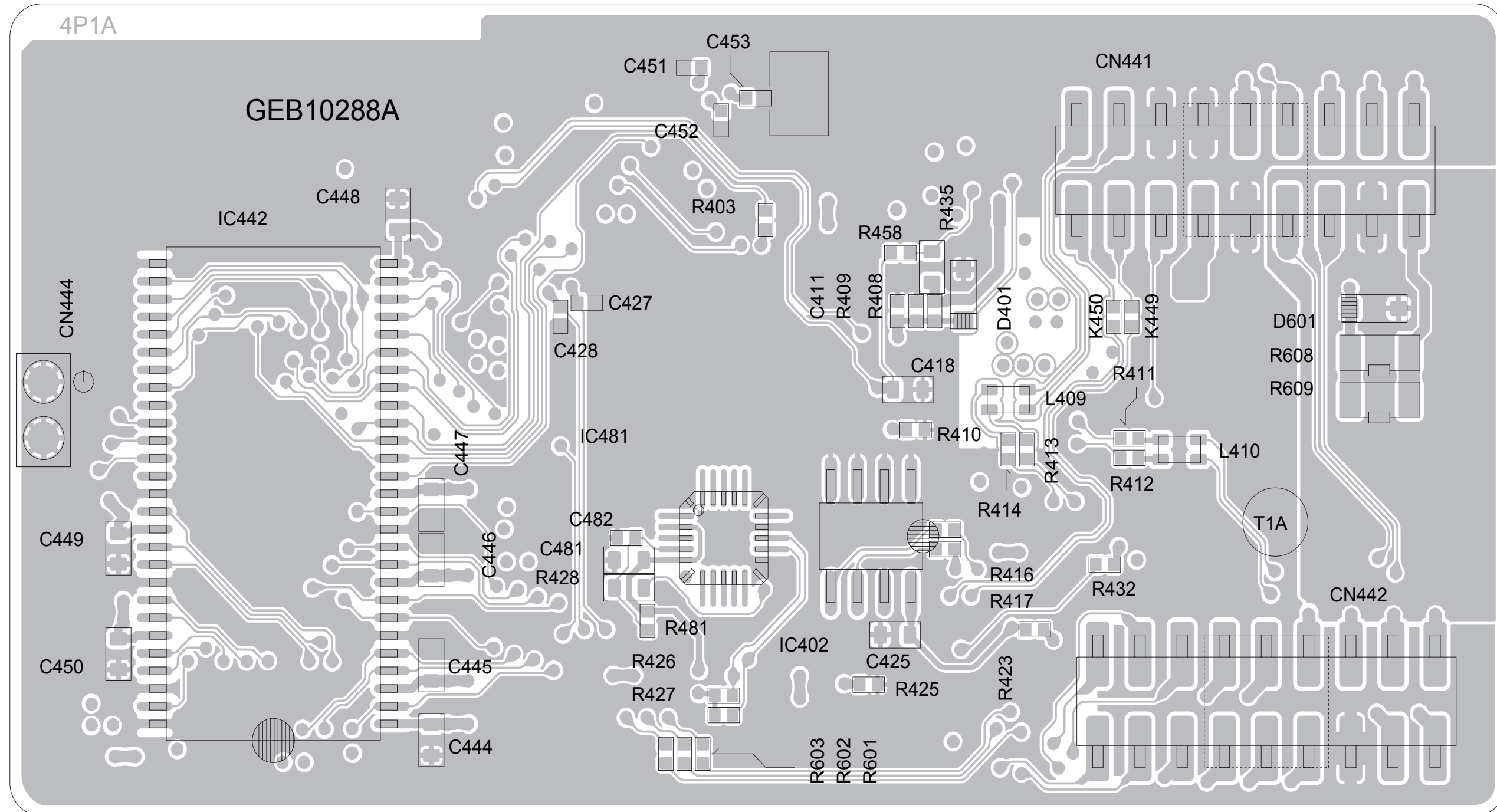

<Mecha control board>

(Lead free solder used in the board (material : Sn-Ag-Cu, melting point : 219 Centigrade))

(Lead free solder used in the board (material : Sn-Cu, melting point : 230 Centigrade))

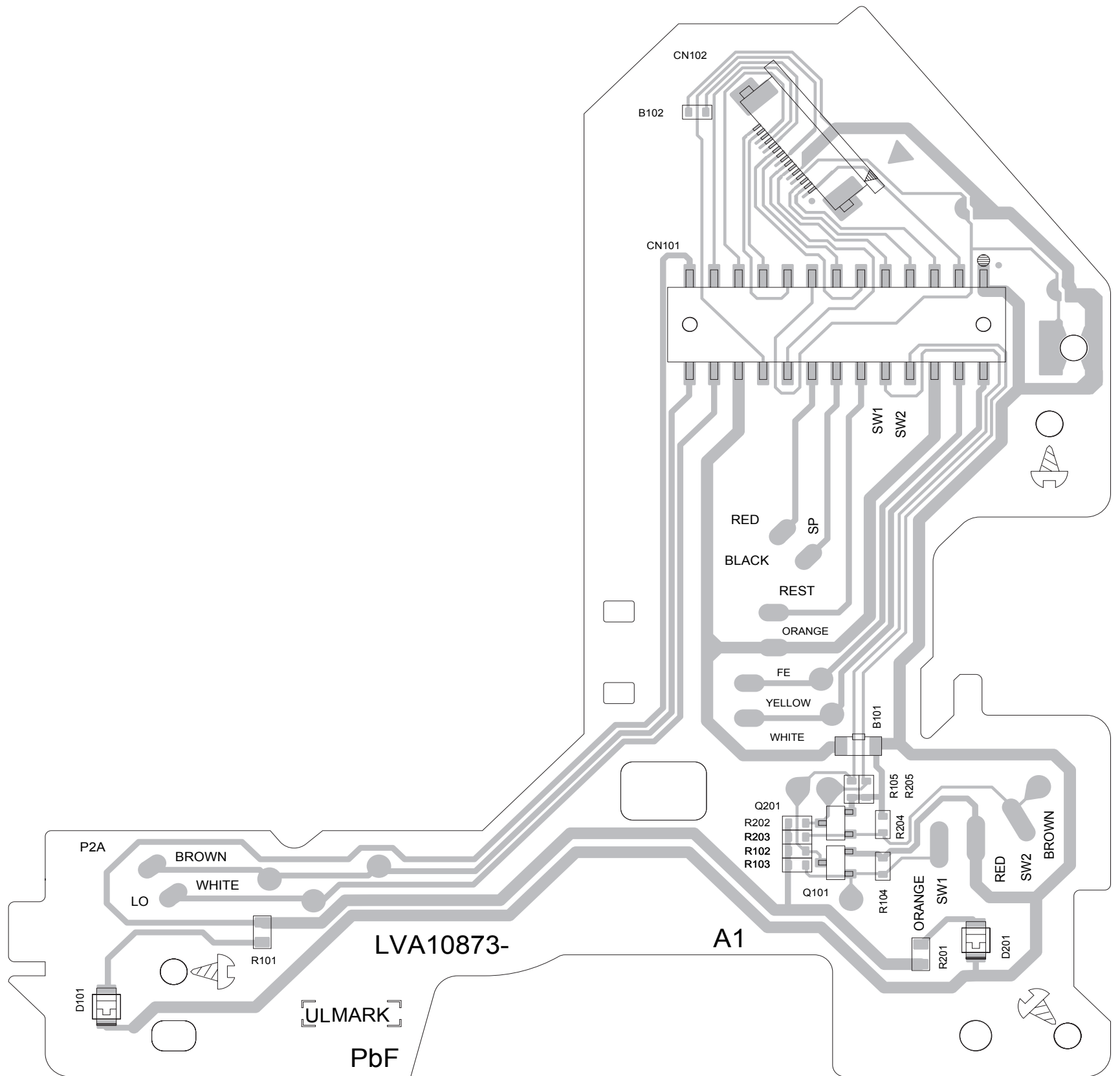

<Photo board>

(Lead free solder used in the board (material : Sn-Ag-Cu, melting point : 219 Centigrade))

(Lead free solder used in the board (material : Sn-Cu, melting point : 230 Centigrade))

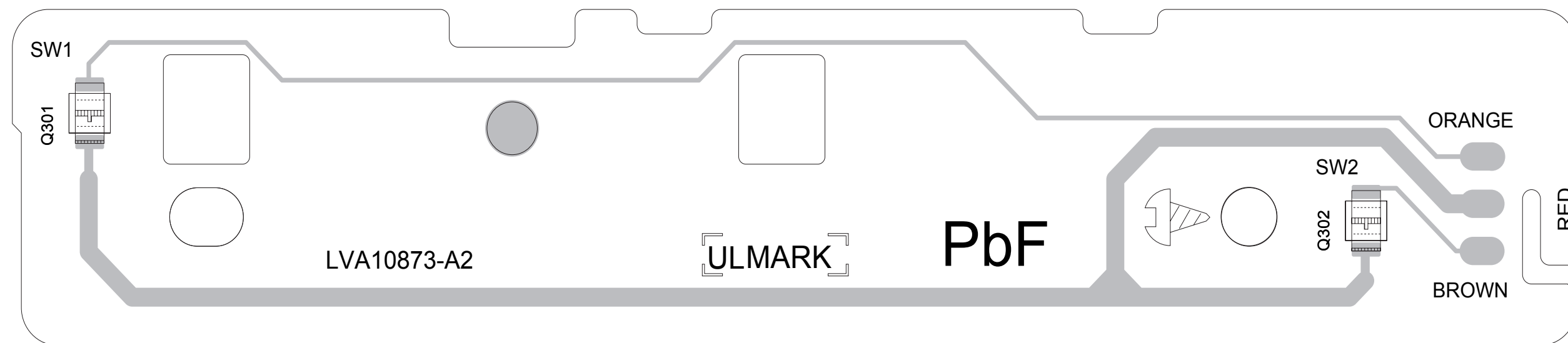

<Rest switch board>

(Lead free solder used in the board (material : Sn-Ag-Cu, melting point : 219 Centigrade))
(Lead free solder used in the board (material : Sn-Cu, melting point : 230 Centigrade))

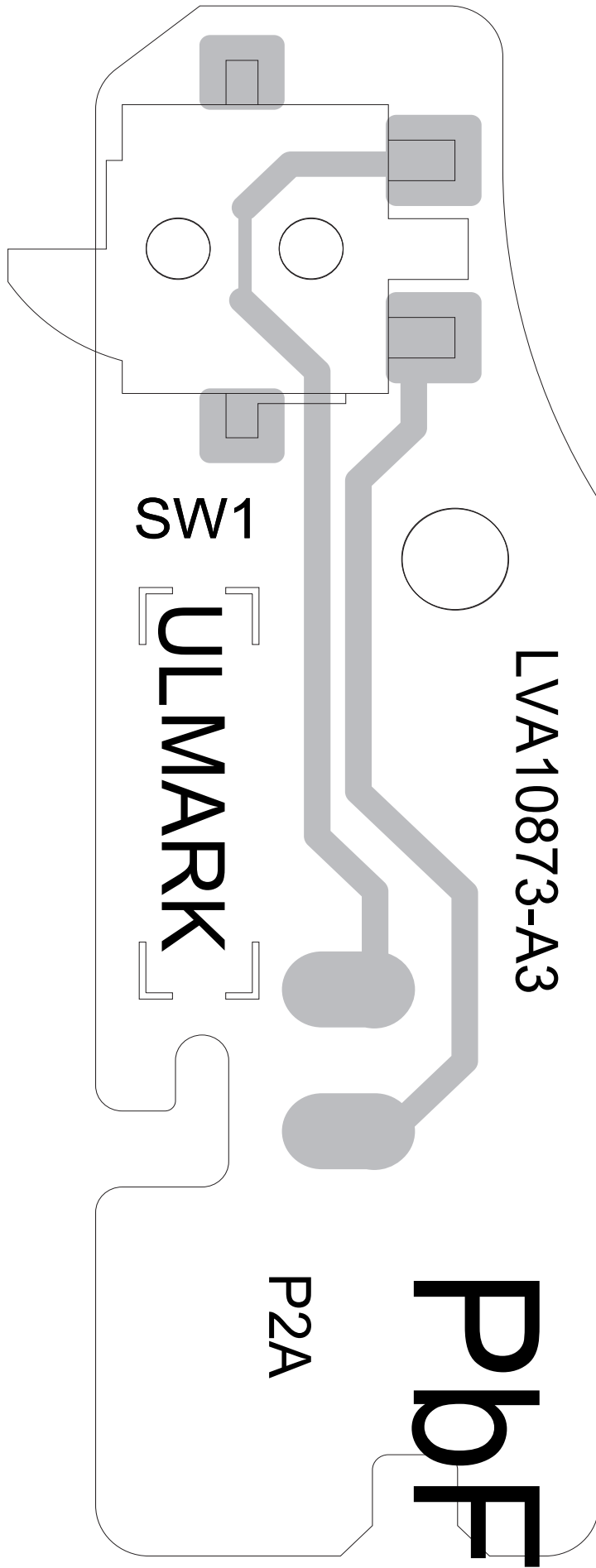

JVC

PARTS LIST

CD RECEIVER

KW-XR810J
KW-XR811E

KW-XR816U
KW-XR811EY
KW-XR817EE

KW-XR816UH
KW-XR811EU



■ PRECAUTIONS ON SCHEMATIC DIAGRAMS

- Due to the improvement in performance, some part numbers shown in the circuit diagrams may not agree with those indicated in the Parts List.
- The parts numbers, values and rated voltage etc. in the Schematic Diagrams are for reference only.
- Since the circuit diagrams are standard ones, the circuits and circuit constants may be subject to change for improvement without any notice.

■ PRECAUTIONS ON PARTS LIST

- The parts identified by the \triangle symbol are critical for safety. Whenever replacing these parts, be sure to use specified ones to secure the safety.
- The parts not indicated in this Parts List and those which are filled with lines --- in the Parts No. columns will not be supplied.
- P.W. BOARD Ass'y will not be supplied, but those which are filled with the Parts No. in the Parts No. columns will be supplied.
- When ordering chips, screws etc., place bulk orders (unit of tens) whenever possible to improve shipping efficiency.
- There are cases where the actual implemented parts in the sets and the service parts are different. When ordering parts, make sure to refer to the Parts List.

■ PRECAUTIONS ON SERVICE

Certain parts of the power circuits and the GNDs differ according to the models. Care must be taken for the following points as the differences are indicated separately in the LIVE GND () and the ISOLATED (NEUTRAL) GND () .

1. Do not touch the LIVE GND, or do not touch the LIVE GND and the ISOLATED (NEUTRAL) GND at the same time. It may cause an electric shock.
Before pulling out the chassis or other parts, make sure to pull out the power cord from the wall outlet first.
2. Do not short circuit between the LIVE GND and ISOLATED (NEUTRAL) GND, or never measure the LIVE GND and ISOLATED (NEUTRAL) GND at the same time using measuring instruments (oscilloscope, etc.). It may blow fuses or damage other parts.

■ DEVIATION TOLERANCE RANGE

DEVIATION TOLERANCE RANGE									
F	G	J	K	M	N	R	H	Z	P
± 1%	± 2%	± 5%	±10%	±20%	±30%	+30% -10%	+50% -10%	+80% -20%	+100% -0%

Exploded view of general assembly

Block No.M1MM

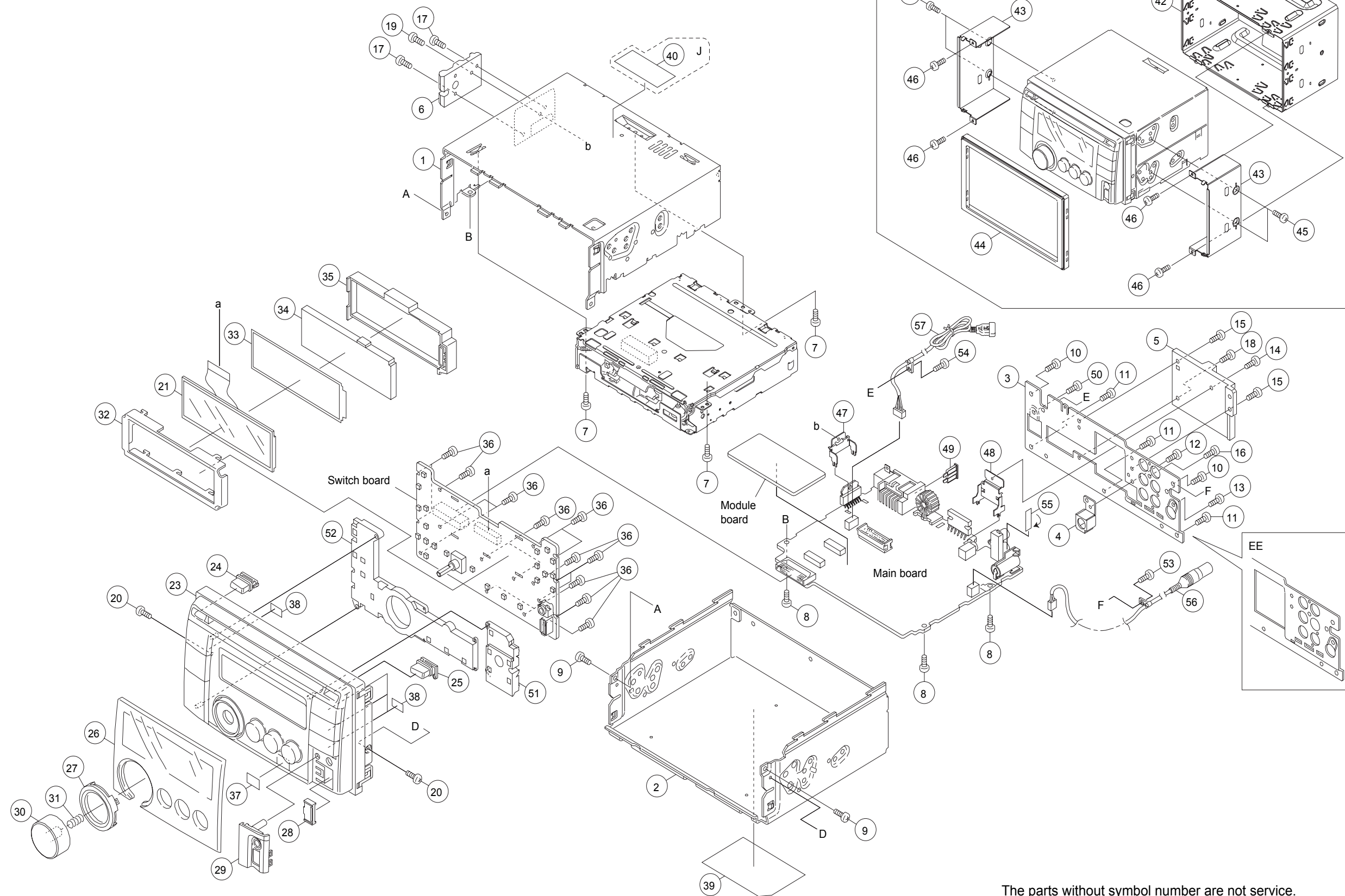
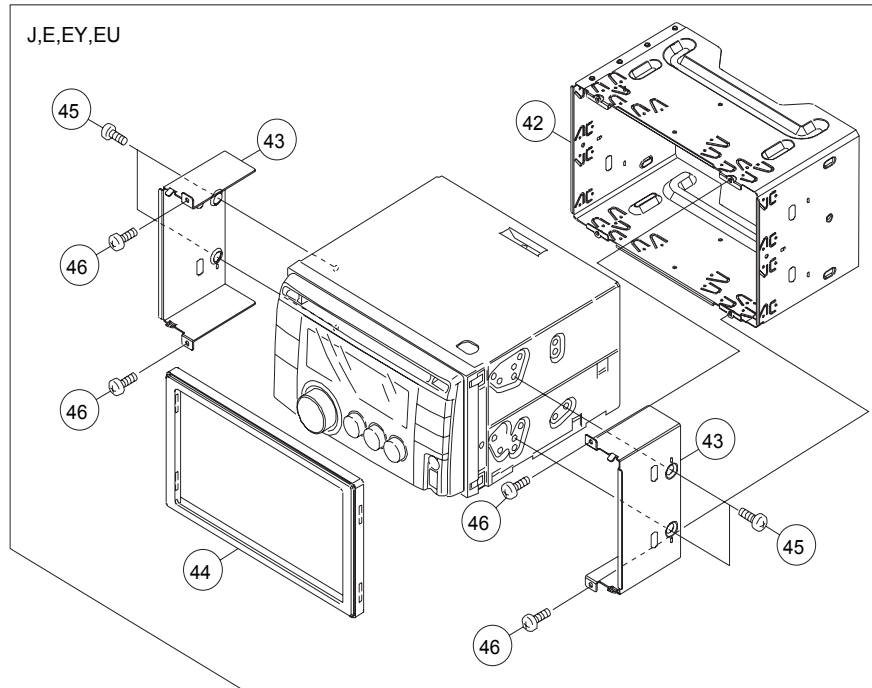

The parts without symbol number are not service.

MODEL	MARK	MODEL	MARK	MODEL	MARK	MODEL	MARK
KW-XR810J	A	KW-XR816U	B	KW-XR816UH	C	KW-XR811E	D
KW-XR811EY	E	KW-XR811EU	F	KW-XR817EE	G		

Safe	Symbol No.	Parts No.	Parts Name	Description	QTY	Local
General assembly <M1MM>						
	1	GE10275-001A	TOP CHASSIS		1	
	2	GE10276-001A	BOTTOM CHASSIS		1	
	3	GE33960-006A	REAR BRACKET		1	A
	3	GE33960-005A	REAR BRACKET		1	B,C,D,E,F
	3	GE33960-004A	REAR BRACKET		1	G
	4	GE33961-001A	OE HOLDER		1	A,B,C,D,E,F
	5	GE33962-001A	HEAT SINK		1	
	6	GE40395-005A	SIDE PANEL		1	
	7	QYSDST2604ZA	TAP SCREW	M2.6 x 4mm	3	
	8	GE40377-002A	SCREW		3	
	9	QYSDST2606ZA	TAP SCREW	M2.6 x 6mm	2	
	10	QYSDST2606ZA	TAP SCREW	M2.6 x 6mm	2	
	11	QYSDST2606ZA	TAP SCREW	M2.6 x 6mm	3	
	12	QYSDST2604ZA	TAP SCREW	M2.6 x 4mm	1	A,B,C,D,E,F
	13	QYSDST2606ZA	TAP SCREW	M2.6 x 6mm	1	A,B,C,G
	14	GE40377-001A	SCREW		1	
	15	GE40377-001A	SCREW		2	
	16	QYSDSF2606ZA	TAP SCREW	M2.6 x 6mm	1	
	17	GE40377-002A	SCREW		2	
	18	GE40377-003A	SPECIAL SCREW		1	
	19	QYSDST2608ZA	TAP SCREW	M2.6 x 8mm	1	
	20	QYSDST2004ZA	TAP SCREW	M2 x 4mm	2	
	21	QLD0640-001	LCD MODULE		1	
	23	GE34021-018A	FRT PANEL ASSY		1	A,B,C
	23	GE34021-019A	FRT PANEL ASSY		1	D,E,F,G
	24	GE33963-001A	EJECT BUTTON		1	
	25	GE33964-001A	DISP BUTTON		1	
	26	GE34022-018A	FINDER ASSY		1	A
	26	GE34022-011A	FINDER ASSY		1	B,C
	26	GE34022-019A	FINDER ASSY		1	D,E,F
	26	GE34022-013A	FINDER ASSY		1	G
	27	GE33966-001A	RIM COVER		1	
	28	GE40408-001A	USB DOOR		1	
	29	GE33967-001A	USB AUX COVER		1	
	30	GE33965-001A	VOLUME KNOB		1	
	31	GE40127-001A	KNOB SPRING		1	
	32	GE33968-001A	LCD CASE 7.6		1	
	33	GE40489-001A	LIGHTING SHEET		1	
	34	GE33971-002A	LCD LENS 4.6		1	
	35	GE33972-001A	LENS CASE 7.6		1	
	36	VKZ4777-010	MINI SCREW		16	
	37	GE40431-004A	REMOTE SHEET		1	
	38	GE40218-0B2A	SHEET		4	
	39	GE34009-001A	NAME PLATE		1	A
	39	GE34012-001A	NAME PLATE		1	B,C
	39	GE34015-002A	NAME PLATE		1	D,E,F
	39	GE34018-001A	NAME PLATE		1	G
	40	GE40442-001A	FCC RULE LABEL		1	A
	42	LV22425-007A	SLEEVE ASSY		1	A,D,E,F,G
	43	LV37151-004A	SUPPORT BKT		2	A,D,E,F,G
	44	GE20225-001A	TRIM PLATE		1	A,D,E,F,G
	45	QYSSSP5008ZA	SCREW	M5 x 8mm	4	A,D,E,F,G
	46	QYSDST2604ZA	TAP SCREW	M2.6 x 4mm	4	A,D,E,F,G
	47	GE40308-001A	REG IC BRACKET		1	
	48	GE40354-001A	IC BRACKET		1	
△	49	QMFZ064-150-J1	FUSE	15A	1	
	50	QYSDST2606ZA	TAP SCREW	M2.6 x 6mm	1	A,D,E,F
	51	GE33977-001A	PRESET LIGHT		1	
	52	GE33978-001A	EQ LIGHT GUIDE		1	
	53	QYSDST2606ZA	TAP SCREW	M2.6 x 6mm	1	
	54	QYSDST2606ZA	TAP SCREW	M2.6 x 6mm	1	
	55	GE40466-003A	SPACER		1	
	56	QAM1002-001	CAR CABLE		1	
	57	QAM1077-001	CAR CABLE		1	
Electrical parts list Main board <01>						
△	IC1	TEF6606T/V5-X	IC		1	
	IC71	LC72725KV-X	IC		1	D,E,F,G
	IC181	NJW1222V-X	IC		1	
	IC201	NJM4565E-X	IC		1	
	IC271	NJM2160BV-X	IC		1	B,C
△	IC301	TDA7851A	IC		1	
	IC361	NJM2792V-X	IC		1	B,C
△	IC501	LA6565-X	IC		1	
	IC521	MN6627553PA	IC		1	
	IC581	NJM4565E-X	IC		1	
△	IC701	JES192B	IC(MCU)		1	A,B,C
△	IC701	JES193A	IC(MCU)		1	D,E,F,G
	IC771	R1EX24016ASAA-X	IC		1	D,E,F,G
	IC801	74AHCT126PW-X	IC		1	A
△	IC901	R2S25400DS-E	IC		1	
	IC902	XC6213B332NG-X	IC		1	
	IC921	NJM2855DL1-33-X	IC		1	
	IC931	TPS54140DGQ-X	IC		1	
	IC941	TPS54140DGQ-X	IC		1	
	Q251	KTD1304-X	TRANSISTOR		1	
	Q322	IMX9-W	PAIR TRANSISTOR		1	
	Q332	IMX9-W	PAIR TRANSISTOR		1	
	Q501	2SB1424/R/-W	TRANSISTOR		1	
	Q502	2SA2188/F/-X	TRANSISTOR		1	

MODEL	MARK	MODEL	MARK	MODEL	MARK	MODEL	MARK
KW-XR810J	A	KW-XR816U	B	KW-XR816UH	C	KW-XR811E	D
KW-XR811EY	E	KW-XR811EU	F	KW-XR817EE	G		

Safe	Symbol No.	Parts No.	Parts Name	Description	QTY	Local
	Q701	2SA812A/5-6/-X	TRANSISTOR		1	
	Q701	or ISA1530AC1/QR/X	TRANSISTOR		1	
	Q702	2SC1623A/5-6/-X	TRANSISTOR		1	
	Q702	or 2SC3928A/QR/-X	TRANSISTOR		1	
	Q703	RT1N141C-X	DIGI TRANSISTOR		1	
	Q703	or UN2211-X	TRANSISTOR		1	
	Q704	RT1P141C-X	DIGI TRANSISTOR		1	
	Q704	or UN2111-X	TRANSISTOR		1	
	Q781	RT1P141C-X	DIGI TRANSISTOR		1	
	Q781	or UN2111-X	TRANSISTOR		1	
	Q782	2SC1623A/5-6/-X	TRANSISTOR		1	
	Q782	or 2SC3928A/QR/-X	TRANSISTOR		1	
	Q784	RT1P141C-X	DIGI TRANSISTOR		1	
	Q784	or UN2111-X	TRANSISTOR		1	
	Q785	RT1P141C-X	DIGI TRANSISTOR		1	
	Q785	or UN2111-X	TRANSISTOR		1	
	Q851	2SB1132/QR/-W	TRANSISTOR		1	B,C
	Q852	RT1N141C-X	DIGI TRANSISTOR		1	B,C
	Q852	or UN2211-X	TRANSISTOR		1	B,C
	Q881	RT1N141C-X	DIGI TRANSISTOR		1	
	Q881	or UN2211-X	TRANSISTOR		1	
	Q976	RT1N141C-X	DIGI TRANSISTOR		1	
	Q976	or UN2211-X	TRANSISTOR		1	
	Q977	2SA812A/5-6/-X	TRANSISTOR		1	
	Q977	or ISA1530AC1/QR/X	TRANSISTOR		1	
	D161	RKZ10B2KG-X	Z DIODE		1	
	D161	or MA8100/M/-X	Z DIODE		1	
	D171	RKZ10B2KG-X	Z DIODE		1	
	D171	or MA8100/M/-X	Z DIODE		1	
	D321	BAW56-TP-X	SI DIODE		1	
	D321	or MC2836-X	DIODE		1	
	D331	BAW56-TP-X	SI DIODE		1	
	D331	or MC2836-X	DIODE		1	
	D477	NAF0029-001X	DIODE	V	1	
	D478	NAF0029-001X	DIODE	V	1	
	D501	GS1J-LTP-X	DIODE		1	
	D502	GS1J-LTP-X	DIODE		1	
	D708	RKZ6.2B2KG-X	Z DIODE		1	
	D708	or MA8062/M/-X	Z DIODE		1	
	D709	RKZ6.2B2KG-X	Z DIODE		1	
	D709	or MA8062/M/-X	Z DIODE		1	
	D710	RKZ6.2B2KG-X	Z DIODE		1	
	D710	or MA8062/M/-X	Z DIODE		1	
	D711	RKZ6.2B2KG-X	Z DIODE		1	
	D711	or MA8062/M/-X	Z DIODE		1	
	D712	RKZ6.2B2KG-X	Z DIODE		1	
	D712	or MA8062/M/-X	Z DIODE		1	
	D713	RKZ6.2B2KG-X	Z DIODE		1	
	D713	or MA8062/M/-X	Z DIODE		1	
	D714	RKZ6.2B2KG-X	Z DIODE		1	A,B,C,D,E,F
	D714	or MA8062/M/-X	Z DIODE		1	A,B,C,D,E,F
	D717	MC2838-X	DIODE		1	
	D717	or MA152WK-X	SI DIODE		1	
	D721	MC2838-X	DIODE		1	
	D721	or MA152WK-X	SI DIODE		1	
	D722	BAW56-TP-X	SI DIODE		1	
	D722	or MC2836-X	DIODE		1	
	D781	HSU119-X	SI DIODE		1	
	D781	or MA111-X	SI DIODE		1	
	D784	RKZ11B2KG-X	Z DIODE		1	
	D784	or MA8110/M/-X	Z DIODE		1	
	D785	HSU119-X	SI DIODE		1	
	D785	or MA111-X	SI DIODE		1	
	D786	HSU119-X	SI DIODE		1	
	D786	or MA111-X	SI DIODE		1	
	D787	HSU119-X	SI DIODE		1	
	D787	or MA111-X	SI DIODE		1	
	D788	HSU119-X	SI DIODE		1	
	D788	or MA111-X	SI DIODE		1	
	D789	1SS380-X	SI DIODE		1	
	D851	MBRX130-TP-X	SB DIODE		1	B,C
	D851	or MA22D23-X	SB DIODE		1	B,C
	D852	MBRX130-TP-X	SB DIODE		1	B,C
	D852	or MA22D23-X	SB DIODE		1	B,C
	D901	1N5401-BPC04	SI DIODE		1	
	D901	or 1N5401-04	SI DIODE		1	
	D902	HSU119-X	SI DIODE		1	
	D902	or MA111-X	SI DIODE		1	
	D931	RB055L-40-X	SB DIODE		1	
	D941	RB055L-40-X	SB DIODE		1	
	D971	MBRX130-TP-X	SB DIODE		1	
	D971	or MA22D23-X	SB DIODE		1	
	D972	MBRX130-TP-X	SB DIODE		1	
	D972	or MA22D23-X	SB DIODE		1	
	C1	NDC31HJ-102X	C CAPACITOR	1000pF 50V J	1	
	C2	NDC31HJ-7R0X	C CAPACITOR	7pF 50V J	1	
	C3	NDC31HJ-102X	C CAPACITOR	1000pF 50V J	1	
	C4	NCB31AK-224X	C CAPACITOR	0.22uF 10V K	1	
	C5	NDC31HJ-150X	C CAPACITOR	15pF 50V J	1	
	C6	NDC31HJ-220X	C CAPACITOR	22pF 50V J	1	
	C10	NCB31AK-105X	C CAPACITOR	1uF 10V K	1	
	C11	NCBA1CK-103W	C CAPACITOR	0.01uF 16V K	1	

MODEL	MARK	MODEL	MARK	MODEL	MARK	MODEL	MARK
KW-XR810J	A	KW-XR816U	B	KW-XR816UH	C	KW-XR811E	D
KW-XR811EY	E	KW-XR811EU	F	KW-XR817EE	G		

Safe	Symbol No.	Parts No.	Parts Name	Description	QTY	Local
	C12	NCBA1CK-103W	C CAPACITOR	0.01uF 16V K	1	
	C13	NCB31AK-105X	C CAPACITOR	1uF 10V K	1	
	C14	NCB31AK-224X	C CAPACITOR	0.22uF 10V K	1	
	C15	NCBA1CK-104W	C CAPACITOR	0.1uF 16V K	1	
	C16	NCBA1CK-103W	C CAPACITOR	0.01uF 16V K	1	
	C17	NCBA1CK-104W	C CAPACITOR	0.1uF 16V K	1	
	C18	NCBA1CK-103W	C CAPACITOR	0.01uF 16V K	1	
	C19	NCBA1CK-104W	C CAPACITOR	0.1uF 16V K	1	
	C22	NDCA1HJ-120W	C CAPACITOR	12pF 50V J	1	
	C23	NCB31CK-104X	C CAPACITOR	0.1uF 16V K	1	
	C24	NCB31HK-103X	C CAPACITOR	0.01uF 50V K	1	
	C25	NCB31HK-103X	C CAPACITOR	0.01uF 50V K	1	
	C26	QEKJ1CM-107Z	E CAPACITOR	100uF 16V M	1	
	C30	QEKJ1CM-107Z	E CAPACITOR	100uF 16V M	1	
	C31	NDC31HJ-102X	C CAPACITOR	1000pF 50V J	1	
	C33	NDC31HJ-5R6X	C CAPACITOR	56pF 50V J	1	
	C71	NDCA1HJ-561W	C CAPACITOR	560pF 50V J	1	D,E,F,G
	C72	NDCA1HJ-331W	C CAPACITOR	330pF 50V J	1	D,E,F,G
	C73	QEKJ1HM-225Z	E CAPACITOR	2.2uF 50V M	1	D,E,F,G
	C74	NDCA1HJ-270W	C CAPACITOR	27pF 50V J	1	D,E,F,G
	C75	NDCA1HJ-270W	C CAPACITOR	27pF 50V J	1	D,E,F,G
	C76	NCBA1CK-103W	C CAPACITOR	0.01uF 16V K	1	D,E,F,G
	C77	QEKJ0JM-476Z	E CAPACITOR	47uF 6.3V M	1	D,E,F,G
	C78	NCBA1CK-103W	C CAPACITOR	0.01uF 16V K	1	D,E,F,G
	C161	NCB31AK-105X	C CAPACITOR	1uF 10V K	1	
	C162	QTE1H64-225Z	E CAPACITOR	2.2uF 50V	1	
	C163	QC20202-155Z	C CAPACITOR	1uF 10V K	1	A
	C164	NCBA1HK-332W	C CAPACITOR	3300pF 50V K	1	
	C165	NCB31AK-105X	C CAPACITOR	1uF 10V K	1	
	C166	NCB31AK-105X	C CAPACITOR	1uF 10V K	1	
	C167	NCB31CK-104X	C CAPACITOR	0.1uF 16V K	1	
	C168	NCB31AK-224X	C CAPACITOR	0.22uF 10V K	1	
	C169	QTE1C57-476Z	E CAPACITOR	47uF 16V	1	
	C171	NCB31AK-105X	C CAPACITOR	1uF 10V K	1	
	C172	QTE1H64-225Z	E CAPACITOR	2.2uF 50V	1	
	C173	QC20202-155Z	C CAPACITOR	1uF 10V K	1	A
	C174	NCBA1HK-332W	C CAPACITOR	3300pF 50V K	1	
	C175	NCB31AK-105X	C CAPACITOR	1uF 10V K	1	
	C179	QTE1A57-107Z	E CAPACITOR	100uF 10V	1	
	C180	NCB31HK-472X	C CAPACITOR	4700pF 50V K	1	
	C181	NCBA1CK-104W	C CAPACITOR	0.1uF 16V K	1	
	C182	NCBA1CK-104W	C CAPACITOR	0.1uF 16V K	1	
	C191	NCBA1CK-104W	C CAPACITOR	0.1uF 16V K	1	
	C192	NCBA1CK-104W	C CAPACITOR	0.1uF 16V K	1	
	C193	NCB31AK-105X	C CAPACITOR	1uF 10V K	1	
	C231	QEKJ1HM-475Z	E CAPACITOR	4.7uF 50V M	1	
	C232	QEKJ1HM-475Z	E CAPACITOR	4.7uF 50V M	1	
	C233	NDCA1HJ-331W	C CAPACITOR	330pF 50V J	1	
	C234	QEKJ1HM-475Z	E CAPACITOR	4.7uF 50V M	1	
	C236	QEKJ1CM-226Z	E CAPACITOR	22uF 16V M	1	
	C238	NDCA1HJ-331W	C CAPACITOR	330pF 50V J	1	
	C239	NCBA1AK-333W	C CAPACITOR	0.033uF 10V K	1	
	C240	NCB31HK-273X	C CAPACITOR	0.027uF 50V K	1	
	C241	NCB31HK-273X	C CAPACITOR	0.027uF 50V K	1	
	C242	NDCA1HJ-220W	C CAPACITOR	22pF 50V J	1	
	C243	NCBA1AK-333W	C CAPACITOR	0.033uF 10V K	1	
	C244	QEKJ1CM-226Z	E CAPACITOR	22uF 16V M	1	
	C245	NCB31CK-104X	C CAPACITOR	0.1uF 16V K	1	
	C271	QEKJ1HM-475Z	E CAPACITOR	4.7uF 50V M	1	B,C
	C272	QEKJ1CM-106Z	E CAPACITOR	10uF 16V M	1	B,C
	C273	QEKJ1CM-107Z	E CAPACITOR	100uF 16V M	1	B,C
	C274	NCB31CK-104X	C CAPACITOR	0.1uF 16V K	1	B,C
	C275	NCB31HK-152X	C CAPACITOR	1500pF 50V K	1	B,C
	C276	QERF1CM-106Z-E	E CAPACITOR	10uF 16V M	1	
	C301	QFV91HJ-474Z	MF CAPACITOR	0.47uF 50V J	1	
	C302	QFV91HJ-474Z	MF CAPACITOR	0.47uF 50V J	1	
	C303	NDC31HJ-560X	C CAPACITOR	56pF 50V J	1	
	C304	NDC31HJ-560X	C CAPACITOR	56pF 50V J	1	
	C306	QTE1H57-475Z	E CAPACITOR	4.7uF 50V	1	
	C307	NCB31HK-103X	C CAPACITOR	0.01uF 50V K	1	
	C308	NCB31HK-103X	C CAPACITOR	0.01uF 50V K	1	
	C311	QFV91HJ-474Z	MF CAPACITOR	0.47uF 50V J	1	
	C312	QFV91HJ-474Z	MF CAPACITOR	0.47uF 50V J	1	
	C313	NDC31HJ-560X	C CAPACITOR	56pF 50V J	1	
	C314	NDC31HJ-560X	C CAPACITOR	56pF 50V J	1	
	C315	NCB31AK-105X	C CAPACITOR	1uF 10V K	1	
	C316	QEKJ1HM-475Z	E CAPACITOR	4.7uF 50V M	1	
	C317	QTE1C57-476Z	E CAPACITOR	47uF 16V	1	
	C318	QTE1H57-475Z	E CAPACITOR	4.7uF 50V	1	
	C319	NCB31EK-223X	C CAPACITOR	0.022uF 25V K	1	
	C320	NCB31EK-223X	C CAPACITOR	0.022uF 25V K	1	
	C330	NDCA1HJ-820W	C CAPACITOR	82pF 50V J	1	
	C361	QEKJ1HM-475Z	E CAPACITOR	4.7uF 50V M	1	B,C,D,E,F,G
	C362	QEKJ1HM-475Z	E CAPACITOR	4.7uF 50V M	1	B,C,D,E,F,G
	C365	QEKJ1HM-475Z	E CAPACITOR	4.7uF 50V M	1	
	C366	QEKJ1HM-475Z	E CAPACITOR	4.7uF 50V M	1	
	C367	QEKJ1AM-227Z	E CAPACITOR	220uF 10V M	1	B,C
	C368	QEKJ1AM-227Z	E CAPACITOR	220uF 10V M	1	B,C
	C369	QEKJ1CM-226Z	E CAPACITOR	22uF 16V M	1	
	C370	NCBA1HK-152W	C CAPACITOR	1500pF 50V K	1	B,C

MODEL	MARK	MODEL	MARK	MODEL	MARK	MODEL	MARK
KW-XR810J	A	KW-XR816U	B	KW-XR816UH	C	KW-XR811E	D
KW-XR811EY	E	KW-XR811EU	F	KW-XR817EE	G		

Safe	Symbol No.	Parts No.	Parts Name	Description	QTY	Local
	C371	NCB31CK-104X	C CAPACITOR	0.1uF 16V K	1	B,C
	C372	NCBA1HK-152W	C CAPACITOR	1500pF 50V K	1	B,C
	C381	QEKJ1HM-475Z	E CAPACITOR	4.7uF 50V M	1	B,C
	C382	QEKJ1HM-475Z	E CAPACITOR	4.7uF 50V M	1	B,C
	C385	QEKJ1HM-475Z	E CAPACITOR	4.7uF 50V M	1	
	C386	QEKJ1HM-475Z	E CAPACITOR	4.7uF 50V M	1	
	C387	QEKJ1CM-107Z	E CAPACITOR	100uF 16V M	1	B,C
	C388	NCB31CK-104X	C CAPACITOR	0.1uF 16V K	1	B,C
	C477	NDC31HJ-220X	C CAPACITOR	22pF 50V J	1	
	C478	NDC31HJ-220X	C CAPACITOR	22pF 50V J	1	
	C493	NCB10JK-106X-A	C CAPACITOR	10uF 6.3V K	1	
	C501	NCBA1HK-222W	C CAPACITOR	2200pF 50V K	1	
	C503	NCB31HK-562X	C CAPACITOR	5600pF 50V K	1	
	C505	NCBA1HK-222W	C CAPACITOR	2200pF 50V K	1	
	C507	NCB31EK-682X	C CAPACITOR	6800pF 25V K	1	
	C509	NDC31HJ-680X	C CAPACITOR	68pF 50V J	1	
	C511	QEKJ1AM-107Z	E CAPACITOR	100uF 10V M	1	
	C512	NCB31CK-104X	C CAPACITOR	0.1uF 16V K	1	
	C513	QEKJ1CM-476Z	E CAPACITOR	47uF 16V M	1	
	C515	QEKJ0JM-107Z	E CAPACITOR	100uF 6.3V M	1	
	C516	NCB31CK-104X	C CAPACITOR	0.1uF 16V K	1	
	C517	NCB31HK-102X	C CAPACITOR	1000pF 50V K	1	
	C520	NCBA1CK-153W	C CAPACITOR	0.015uF 16V K	1	
	C521	NCBA1AK-104W	C CAPACITOR	0.1uF 10V K	1	
	C522	NCBA1HK-102W	C CAPACITOR	1000pF 50V K	1	
	C523	NCB31CK-823X	C CAPACITOR	0.082uF 16V K	1	
	C525	NCBA1HK-102W	C CAPACITOR	1000pF 50V K	1	
	C526	NCB31AK-334X	C CAPACITOR	0.33uF 10V K	1	
	C527	NCBA1AK-104W	C CAPACITOR	0.1uF 10V K	1	
	C528	QEKJ1CM-106Z	E CAPACITOR	10uF 16V M	1	
	C530	NCBA1AK-104W	C CAPACITOR	0.1uF 10V K	1	
	C531	NCBA1AK-104W	C CAPACITOR	0.1uF 10V K	1	
	C532	QEKJ1CM-106Z	E CAPACITOR	10uF 16V M	1	
	C533	NCBA1AK-104W	C CAPACITOR	0.1uF 10V K	1	
	C534	NCBA1AK-104W	C CAPACITOR	0.1uF 10V K	1	
	C535	QEKJ1CM-106Z	E CAPACITOR	10uF 16V M	1	
	C538	NCBA1AK-104W	C CAPACITOR	0.1uF 10V K	1	
	C541	QEKJ1CM-106Z	E CAPACITOR	10uF 16V M	1	
	C542	NCBA1AK-104W	C CAPACITOR	0.1uF 10V K	1	
	C543	QEKJ1CM-106Z	E CAPACITOR	10uF 16V M	1	
	C544	NCBA1AK-104W	C CAPACITOR	0.1uF 10V K	1	
	C545	QEKJ0JM-476Z	E CAPACITOR	47uF 6.3V M	1	
	C546	NCBA1AK-104W	C CAPACITOR	0.1uF 10V K	1	
	C547	NCB31AK-154X	C CAPACITOR	0.15uF 10V K	1	
	C549	NCB31HK-272X	C CAPACITOR	2700pF 50V K	1	
	C550	QEKJ0JM-476Z	E CAPACITOR	47uF 6.3V M	1	
	C551	NCBA1AK-104W	C CAPACITOR	0.1uF 10V K	1	
	C552	NCBA1CK-223W	C CAPACITOR	0.022uF 16V K	1	
	C553	NCBA1HK-332W	C CAPACITOR	3300pF 50V K	1	
	C554	NCB31AK-334X	C CAPACITOR	0.33uF 10V K	1	
	C555	NCJ21CK-475X-FR	C CAPACITOR	4.7uF 16V K	1	
	C556	NCBA1AK-104W	C CAPACITOR	0.1uF 10V K	1	
	C557	NDC31HJ-681X	C CAPACITOR	680pF 50V J	1	
	C558	QEKJ0JM-476Z	E CAPACITOR	47uF 6.3V M	1	
	C559	QEKJ0JM-476Z	E CAPACITOR	47uF 6.3V M	1	
	C560	NCB31CK-104X	C CAPACITOR	0.1uF 16V K	1	
	C561	NCB31CK-104X	C CAPACITOR	0.1uF 16V K	1	
	C562	NCB31CK-104X	C CAPACITOR	0.1uF 16V K	1	
	C583	NDCA1HJ-821W	C CAPACITOR	820pF 50V J	1	
	C584	NDCA1HJ-821W	C CAPACITOR	820pF 50V J	1	
	C585	QTE1H57-475Z	E CAPACITOR	4.7uF 50V	1	
	C586	QTE1H57-475Z	E CAPACITOR	4.7uF 50V	1	
	C587	NDCA1HJ-151W	C CAPACITOR	150pF 50V J	1	
	C588	NDCA1HJ-151W	C CAPACITOR	150pF 50V J	1	
	C590	QTE0J57-476Z	E CAPACITOR	47uF 6.3V	1	
	C591	QTE1A57-107Z	E CAPACITOR	100uF 10V	1	
	C592	NCB31CK-104X	C CAPACITOR	0.1uF 16V K	1	
	C701	NDCA1HJ-220W	C CAPACITOR	22pF 50V J	1	
	C702	NDCA1HJ-270W	C CAPACITOR	27pF 50V J	1	
	C705	NDC31HJ-220X	C CAPACITOR	22pF 50V J	1	
	C706	NDC31HJ-220X	C CAPACITOR	22pF 50V J	1	
	C707	NCB31HK-104X	C CAPACITOR	0.1uF 50V K	1	
	C709	NCB31HK-104X	C CAPACITOR	0.1uF 50V K	1	
	C710	NCB31HK-104X	C CAPACITOR	0.1uF 50V K	1	
	C711	NDC31HJ-470X	C CAPACITOR	47pF 50V J	1	
	C713	NDC31HJ-470X	C CAPACITOR	47pF 50V J	1	
	C714	NDC31HJ-101X	C CAPACITOR	100pF 50V J	1	A,B,C,D,E,F
	C715	NCBA1AK-104W	C CAPACITOR	0.1uF 10V K	1	
	C716	NCB31AK-105X	C CAPACITOR	1uF 10V K	1	
	C717	NCBA1CK-473W	C CAPACITOR	0.047uF 16V K	1	
	C718	NCBA1CK-103W	C CAPACITOR	0.01uF 16V K	1	
	C720	NCB31CK-473X	C CAPACITOR	0.047uF 16V K	1	
	C721	NCB31CK-473X	C CAPACITOR	0.047uF 16V K	1	
	C722	NCB31HK-103X	C CAPACITOR	0.01uF 50V K	1	
	C723	QEKJ0JM-337Z	E CAPACITOR	330uF 6.3V M	1	
	C726	NCB31HK-471X	C CAPACITOR	470pF 50V K	1	
	C727	NCBA1CK-473W	C CAPACITOR	0.047uF 16V K	1	
	C731	NCB31EK-473X	C CAPACITOR	0.047uF 25V K	1	
	C732	NCB31EK-473X	C CAPACITOR	0.047uF 25V K	1	
	C733	QEKJ1CM-106Z	E CAPACITOR	10uF 16V M	1	
	C771	NCBA1AK-473W	C CAPACITOR	0.047uF 10V K	1	D,E,F,G
	C781	QEKJ0JM-107Z	E CAPACITOR	100uF 6.3V M	1	

MODEL	MARK	MODEL	MARK	MODEL	MARK	MODEL	MARK
KW-XR810J	A	KW-XR816U	B	KW-XR816UH	C	KW-XR811E	D
KW-XR811EY	E	KW-XR811EU	F	KW-XR817EE	G		

Safe	Symbol No.	Parts No.	Parts Name	Description	QTY	Local
	C784	QEKJ1CM-107Z	E CAPACITOR	100uF 16V M	1	
	C785	QEKJ0JM-476Z	E CAPACITOR	47uF 6.3V M	1	
	C786	NCBA1AK-104W	C CAPACITOR	0.1uF 10V K	1	
	C851	QEKJ1EM-106Z	E CAPACITOR	10uF 25V M	1	B,C
	C852	NCB31CK-224X	C CAPACITOR	0.22uF 16V K	1	B,C
	C881	QEKJ1CM-226Z	E CAPACITOR	22uF 16V M	1	
	C901	QE20869-278	E CAPACITOR	2700uF	1	
	C903	QEKJ1CM-476Z	E CAPACITOR	47uF 16V M	1	
	C904	QEKJ1CM-106Z	E CAPACITOR	10uF 16V M	1	
	C905	QEKJ1CM-476Z	E CAPACITOR	47uF 16V M	1	
	C906	NCB31HK-103X	C CAPACITOR	0.01uF 50V K	1	
	C907	QEKJ1CM-107Z	E CAPACITOR	100uF 16V M	1	
	C908	QERF1AM-227Z	E CAPACITOR	220uF 10V M	1	
	C909	QERF0JM-337Z	E CAPACITOR	330uF 6.3V M	1	
	C910	QEKJ1CM-106Z	E CAPACITOR	10uF 16V M	1	
	C911	NCB31EK-104X	C CAPACITOR	0.1uF 25V K	1	
	C912	NCB31HK-103X	C CAPACITOR	0.01uF 50V K	1	
	C913	QEKJ1CM-106Z	E CAPACITOR	10uF 16V M	1	
	C915	NCB31EK-104X	C CAPACITOR	0.1uF 25V K	1	
	C916	NCB31HK-103X	C CAPACITOR	0.01uF 50V K	1	
	C918	NCB31HK-103X	C CAPACITOR	0.01uF 50V K	1	
	C921	NCB31AK-105X	C CAPACITOR	1uF 10V K	1	
	C922	QEKJ0JM-107Z	E CAPACITOR	100uF 6.3V M	1	
	C923	NCB31AK-105X	C CAPACITOR	1uF 10V K	1	
	C925	NCB31HK-103X	C CAPACITOR	0.01uF 50V K	1	
	C926	NCB31HK-104X	C CAPACITOR	0.1uF 50V K	1	
	C928	QEKJ1EM-476Z	E CAPACITOR	47uF 25V M	1	
	C929	QEKJ1EM-476Z	E CAPACITOR	47uF 25V M	1	
	C930	NCJ11EK-106X-A	C CAPACITOR	10uF 25V K	1	
	C931	NCJ11EK-106X-A	C CAPACITOR	10uF 25V K	1	
	C932	NCJ11EK-106X-A	C CAPACITOR	10uF 25V K	1	
	C933	NCBA1CK-104W	C CAPACITOR	0.1uF 16V K	1	
	C934	NCB31CK-104X	C CAPACITOR	0.1uF 16V K	1	
	C935	NCB31HK-272X	C CAPACITOR	2700pF 50V K	1	
	C936	NDC31HJ-5R6X	C CAPACITOR	5.6pF 50V J	1	
	C937	NCB10JK-106X-A	C CAPACITOR	10uF 6.3V K	1	
	C938	NCB10JK-106X-A	C CAPACITOR	10uF 6.3V K	1	
	C939	NDCA1HJ-100W	C CAPACITOR	10pF 50V J	1	
	C940	NCJ11EK-106X-A	C CAPACITOR	10uF 25V K	1	
	C941	NCJ11EK-106X-A	C CAPACITOR	10uF 25V K	1	
	C942	NCJ11EK-106X-A	C CAPACITOR	10uF 25V K	1	
	C943	NCBA1CK-104W	C CAPACITOR	0.1uF 16V K	1	
	C944	NCB31CK-104X	C CAPACITOR	0.1uF 16V K	1	
	C945	NCB31HK-272X	C CAPACITOR	2700pF 50V K	1	
	C946	NDC31HJ-5R6X	C CAPACITOR	5.6pF 50V J	1	
	C947	NCB10JK-106X-A	C CAPACITOR	10uF 6.3V K	1	
	C948	NCB10JK-106X-A	C CAPACITOR	10uF 6.3V K	1	
	C949	NDCA1HJ-100W	C CAPACITOR	10pF 50V J	1	
	C950	QEKJ0JM-107Z	E CAPACITOR	100uF 6.3V M	1	
	C951	QEKJ0JM-107Z	E CAPACITOR	100uF 6.3V M	1	
	C971	NCB31EK-104X	C CAPACITOR	0.1uF 25V K	1	
	C985	NRSA63J-0R0X	MG RESISTOR	0Ω 1/10W J	1	
	C988	NCB31HK-472X	C CAPACITOR	4700pF 50V K	1	
	R1	NRSA63J-474X	MG RESISTOR	470kΩ 1/16W J	1	
	R2	NRSA63J-474X	MG RESISTOR	470kΩ 1/16W J	1	
	R3	NRSA63J-101X	MG RESISTOR	100Ω 1/16W J	1	
	R4	NRSA6AJ-472W	MG RESISTOR	4.7kΩ 1/16W J	1	
	R5	NRSA02J-470X	MG RESISTOR	47Ω 1/10W J	1	
	R6	NRSA6AJ-101W	MG RESISTOR	100Ω 1/16W J	1	
	R7	NRSA6AJ-101W	MG RESISTOR	100Ω 1/16W J	1	
	R8	NRSA02J-470X	MG RESISTOR	47Ω 1/10W J	1	
	R11	NRS181J-4R7X	MG RESISTOR	4.7Ω 1/8W J	1	
	R14	NRSA6AJ-472W	MG RESISTOR	4.7kΩ 1/16W J	1	
	R15	NRSA6AJ-472W	MG RESISTOR	4.7kΩ 1/16W J	1	
	R71	NRSA6AJ-0R0W	MG RESISTOR	0Ω 1/16W J	1	D,E,F,G
	R72	NRSA6AJ-222W	MG RESISTOR	2.2kΩ 1/16W J	1	D,E,F,G
	R73	NRSA6AJ-222W	MG RESISTOR	2.2kΩ 1/16W J	1	D,E,F,G
	R74	NRSA02J-0R0X	MG RESISTOR	0Ω 1/10W J	1	D,E,F,G
	R166	NRSA6AJ-473W	MG RESISTOR	47kΩ 1/16W J	1	
	R167	NRSA63J-471X	MG RESISTOR	470Ω 1/16W J	1	
	R176	NRSA6AJ-473W	MG RESISTOR	47kΩ 1/16W J	1	
	R186	NRSA6AJ-0R0W	MG RESISTOR	0Ω 1/16W J	1	
	R189	NRSA6AJ-101W	MG RESISTOR	100Ω 1/16W J	1	
	R195	NRSA6AJ-0R0W	MG RESISTOR	0Ω 1/16W J	1	
	R202	NRSA6AJ-103W	MG RESISTOR	10kΩ 1/16W J	1	
	R230	NRSA6AJ-822W	MG RESISTOR	8.2kΩ 1/16W J	1	
	R231	NRSA6AJ-122W	MG RESISTOR	1.2kΩ 1/16W J	1	
	R232	NRSA6AJ-122W	MG RESISTOR	1.2kΩ 1/16W J	1	
	R233	NRSA6AJ-124W	MG RESISTOR	120kΩ 1/16W J	1	
	R234	NRSA6AJ-333W	MG RESISTOR	33kΩ 1/16W J	1	
	R235	NRSA6AJ-822W	MG RESISTOR	8.2kΩ 1/16W J	1	
	R237	NRSA6AJ-103W	MG RESISTOR	10kΩ 1/16W J	1	
	R238	NRSA6AJ-124W	MG RESISTOR	120kΩ 1/16W J	1	
	R239	NRSA6AJ-103W	MG RESISTOR	10kΩ 1/16W J	1	
	R240	NRSA6AJ-822W	MG RESISTOR	8.2kΩ 1/16W J	1	
	R241	NRSA6AJ-0R0W	MG RESISTOR	0Ω 1/16W J	1	
	R242	NRSA6AJ-0R0W	MG RESISTOR	0Ω 1/16W J	1	
	R243	NRSA02J-100X	MG RESISTOR	10Ω 1/10W J	1	
	R271	NRSA6AJ-223W	MG RESISTOR	22kΩ 1/16W J	1	B,C
	R272	NRSA63J-333X	MG RESISTOR	33kΩ 1/16W J	1	B,C

MODEL	MARK	MODEL	MARK	MODEL	MARK	MODEL	MARK
KW-XR810J	A	KW-XR816U	B	KW-XR816UH	C	KW-XR811E	D
KW-XR811EY	E	KW-XR811EU	F	KW-XR817EE	G		

Safe	Symbol No.	Parts No.	Parts Name	Description	QTY	Local
	R273	NRSA6AJ-0R0W	MG RESISTOR	0Ω 1/16W J	1	A,D,E,F,G
	R274	NRSA6AJ-333W	MG RESISTOR	33kΩ 1/16W J	1	
	R275	NRSA63J-821X	MG RESISTOR	820Ω 1/16W J	1	
	R276	NRSA63J-101X	MG RESISTOR	100Ω 1/16W J	1	
	R277	NRSA6AJ-472W	MG RESISTOR	4.7kΩ 1/16W J	1	
	R278	NRSA63J-101X	MG RESISTOR	100Ω 1/16W J	1	
	R301	NRSA6AJ-102W	MG RESISTOR	1kΩ 1/16W J	1	
	R302	NRSA6AJ-102W	MG RESISTOR	1kΩ 1/16W J	1	
	R304	NRSA6AJ-102W	MG RESISTOR	1kΩ 1/16W J	1	
	R309	NRSA02J-100X	MG RESISTOR	10Ω 1/10W J	1	
	R310	NRSA6AJ-472W	MG RESISTOR	4.7kΩ 1/16W J	1	
	R311	NRSA6AJ-102W	MG RESISTOR	1kΩ 1/16W J	1	
	R312	NRSA6AJ-102W	MG RESISTOR	1kΩ 1/16W J	1	
	R321	NRSA6AJ-222W	MG RESISTOR	2.2kΩ 1/16W J	1	
	R322	NRSA63J-821X	MG RESISTOR	820Ω 1/16W J	1	
	R323	NRSA63J-101X	MG RESISTOR	100Ω 1/16W J	1	
	R331	NRSA6AJ-222W	MG RESISTOR	2.2kΩ 1/16W J	1	
	R332	NRSA63J-821X	MG RESISTOR	820Ω 1/16W J	1	
	R333	NRSA63J-101X	MG RESISTOR	100Ω 1/16W J	1	
	R341	NRSA6AJ-222W	MG RESISTOR	2.2kΩ 1/16W J	1	
	R342	NRSA63J-821X	MG RESISTOR	820Ω 1/16W J	1	
	R343	NRSA63J-101X	MG RESISTOR	100Ω 1/16W J	1	
	R351	NRSA6AJ-222W	MG RESISTOR	2.2kΩ 1/16W J	1	
	R352	NRSA63J-821X	MG RESISTOR	820Ω 1/16W J	1	
	R353	NRSA63J-101X	MG RESISTOR	100Ω 1/16W J	1	
	R361	NRSA6AJ-333W	MG RESISTOR	33kΩ 1/16W J	1	B,C
	R362	NRSA6AJ-223W	MG RESISTOR	22kΩ 1/16W J	1	B,C
	R363	NRSA6AJ-473W	MG RESISTOR	47kΩ 1/16W J	1	
	R365	NRSA6AJ-333W	MG RESISTOR	33kΩ 1/16W J	1	B,C
	R366	NRSA6AJ-223W	MG RESISTOR	22kΩ 1/16W J	1	B,C
	R367	NRSA6AJ-473W	MG RESISTOR	47kΩ 1/16W J	1	
	R371	NRSA6AJ-0R0W	MG RESISTOR	0Ω 1/16W J	1	A,D,E,F,G
	R372	NRSA6AJ-0R0W	MG RESISTOR	0Ω 1/16W J	1	A,D,E,F,G
	R373	NRSA6AJ-0R0W	MG RESISTOR	0Ω 1/16W J	1	A,D,E,F,G
	R374	NRSA6AJ-0R0W	MG RESISTOR	0Ω 1/16W J	1	A,D,E,F,G
	R381	NRSA6AJ-333W	MG RESISTOR	33kΩ 1/16W J	1	B,C
	R382	NRSA6AJ-223W	MG RESISTOR	22kΩ 1/16W J	1	B,C
	R383	NRSA6AJ-473W	MG RESISTOR	47kΩ 1/16W J	1	
	R385	NRSA6AJ-333W	MG RESISTOR	33kΩ 1/16W J	1	B,C
	R386	NRSA6AJ-223W	MG RESISTOR	22kΩ 1/16W J	1	B,C
	R387	NRSA6AJ-473W	MG RESISTOR	47kΩ 1/16W J	1	
	R477	NRSA63J-153X	MG RESISTOR	15kΩ 1/16W J	1	
	R478	NRSA63J-153X	MG RESISTOR	15kΩ 1/16W J	1	
	R502	NRSA63J-682X	MG RESISTOR	6.8kΩ 1/16W J	1	
	R503	NRSA6AJ-333W	MG RESISTOR	33kΩ 1/16W J	1	
	R504	NRSA6AJ-822W	MG RESISTOR	8.2kΩ 1/16W J	1	
	R505	NRSA6AJ-822W	MG RESISTOR	8.2kΩ 1/16W J	1	
	R507	NRSA6AJ-222W	MG RESISTOR	2.2kΩ 1/16W J	1	
	R508	NRSA6AJ-103W	MG RESISTOR	10kΩ 1/16W J	1	
	R509	NRSA6AJ-822W	MG RESISTOR	8.2kΩ 1/16W J	1	
	R510	NRSA6AJ-822W	MG RESISTOR	8.2kΩ 1/16W J	1	
	R511	NRSA6AJ-562W	MG RESISTOR	5.6kΩ 1/16W J	1	
	R512	NRSA6AJ-153W	MG RESISTOR	15kΩ 1/16W J	1	
	R513	NRSA6AJ-153W	MG RESISTOR	15kΩ 1/16W J	1	
	R514	NRSA6AJ-822W	MG RESISTOR	8.2kΩ 1/16W J	1	
	R515	NRSA6AJ-562W	MG RESISTOR	5.6kΩ 1/16W J	1	
	R516	NRSA6AJ-103W	MG RESISTOR	10kΩ 1/16W J	1	
	R517	NRSA6AJ-682W	MG RESISTOR	6.8kΩ 1/16W J	1	
	R518	NRSA6AJ-822W	MG RESISTOR	8.2kΩ 1/16W J	1	
	R519	NRSA6AJ-473W	MG RESISTOR	47kΩ 1/16W J	1	
	R520	NRS125J-100X	MG RESISTOR	10Ω 1/2W J	1	
	R521	NRSA6AJ-822W	MG RESISTOR	8.2kΩ 1/16W J	1	
	R522	NRSA6AJ-512W	MG RESISTOR	5.1kΩ 1/16W J	1	
	R523	NRSA6AJ-333W	MG RESISTOR	33kΩ 1/16W J	1	
	R524	NRSA6AJ-683W	MG RESISTOR	68kΩ 1/16W J	1	
	R525	NRSA63J-151X	MG RESISTOR	150Ω 1/16W J	1	
	R528	NRSA63J-220X	MG RESISTOR	22Ω 1/16W J	1	
	R531	NRSA63J-0R0X	MG RESISTOR	0Ω 1/10W J	1	
	R532	NRSA6AJ-822W	MG RESISTOR	8.2kΩ 1/16W J	1	
	R533	NRSA6AJ-822W	MG RESISTOR	8.2kΩ 1/16W J	1	
	R534	NRSA6AJ-0R0W	MG RESISTOR	0Ω 1/16W J	1	
	R535	NRSA6AJ-0R0W	MG RESISTOR	0Ω 1/16W J	1	
	R536	NRSA6AJ-0R0W	MG RESISTOR	0Ω 1/16W J	1	
	R537	NRSA02J-100X	MG RESISTOR	10Ω 1/10W J	1	
	R538	NRSA02J-100X	MG RESISTOR	10Ω 1/10W J	1	
	R539	NRSA6AJ-473W	MG RESISTOR	47kΩ 1/16W J	1	
	R540	NRSA6AJ-821W	MG RESISTOR	820Ω 1/16W J	1	
	R541	NRSA6AJ-272W	MG RESISTOR	2.7kΩ 1/16W J	1	
	R542	NRSA6AJ-823W	MG RESISTOR	82kΩ 1/16W J	1	
	R544	NRSA6AJ-0R0W	MG RESISTOR	0Ω 1/16W J	1	
	R546	NRSA6AJ-103W	MG RESISTOR	10kΩ 1/16W J	1	
	R547	NRSA6AJ-102W	MG RESISTOR	1kΩ 1/16W J	1	
	R548	NRSA6AJ-221W	MG RESISTOR	220Ω 1/16W J	1	
	R549	NRSA6AJ-105W	MG RESISTOR	1MΩ 1/16W J	1	
	R550	NRSA6AJ-102W	MG RESISTOR	1kΩ 1/16W J	1	
	R551	NRSA6AJ-102W	MG RESISTOR	1kΩ 1/16W J	1	
	R552	NRSA6AJ-220W	MG RESISTOR	22Ω 1/16W J	1	
	R553	NRSA6AJ-0R0W	MG RESISTOR	0Ω 1/16W J	1	
	R554	NRSA63J-0R0X	MG RESISTOR	0Ω 1/10W J	1	
	R583	NRSA6AJ-243W	MG RESISTOR	24kΩ 1/16W J	1	
	R584	NRSA6AJ-243W	MG RESISTOR	24kΩ 1/16W J	1	
	R585	NRSA6AJ-822W	MG RESISTOR	8.2kΩ 1/16W J	1	

MODEL	MARK	MODEL	MARK	MODEL	MARK	MODEL	MARK
KW-XR810J	A	KW-XR816U	B	KW-XR816UH	C	KW-XR811E	D
KW-XR811EY	E	KW-XR811EU	F	KW-XR817EE	G		

Safe	Symbol No.	Parts No.	Parts Name	Description	QTY	Local
	R586	NRSA6AJ-822W	MG RESISTOR	8.2kΩ 1/16W J	1	
	R587	NRSA6AJ-273W	MG RESISTOR	27kΩ 1/16W J	1	
	R588	NRSA6AJ-273W	MG RESISTOR	27kΩ 1/16W J	1	
	R591	NRSA6AJ-103W	MG RESISTOR	10kΩ 1/16W J	1	
	R592	NRSA6AJ-103W	MG RESISTOR	10kΩ 1/16W J	1	
	R593	NRSA6AJ-103W	MG RESISTOR	10kΩ 1/16W J	1	
	R594	NRSA6AJ-103W	MG RESISTOR	10kΩ 1/16W J	1	
	R599	NRSA63J-0R0X	MG RESISTOR	0Ω 1/10W J	1	
	R601	NRS125J-100X	MG RESISTOR	10Ω 1/2W J	1	
	R603	NRSA63J-0R0X	MG RESISTOR	0Ω 1/10W J	1	
	R701	NRSA6AJ-473W	MG RESISTOR	47kΩ 1/16W J	1	
	R702	NRSA6AJ-106W	MG RESISTOR	10MΩ 1/16W J	1	
	R703	NRSA6AJ-0R0W	MG RESISTOR	0Ω 1/16W J	1	
	R705	NRSA63J-0R0X	MG RESISTOR	0Ω 1/10W J	1	
	R707	NRSA6AJ-223W	MG RESISTOR	22kΩ 1/16W J	1	
	R709	NRSA6AJ-123W	MG RESISTOR	12kΩ 1/16W J	1	
	R710	NRSA6AJ-123W	MG RESISTOR	12kΩ 1/16W J	1	
	R711	NRSA6AJ-103W	MG RESISTOR	10kΩ 1/16W J	1	
	R712	NRSA6AJ-101W	MG RESISTOR	100Ω 1/16W J	1	
	R713	NRSA6AJ-473W	MG RESISTOR	47kΩ 1/16W J	1	
	R714	NRSA6AJ-473W	MG RESISTOR	47kΩ 1/16W J	1	
	R715	NRSA6AJ-473W	MG RESISTOR	47kΩ 1/16W J	1	
	R719	NRSA6AJ-473W	MG RESISTOR	47kΩ 1/16W J	1	
	R721	NRSA63J-101X	MG RESISTOR	100Ω 1/16W J	1	
	R722	NRSA6AJ-473W	MG RESISTOR	47kΩ 1/16W J	1	
	R723	NRSA6AJ-222W	MG RESISTOR	2.2kΩ 1/16W J	1	
	R724	NRSA6AJ-222W	MG RESISTOR	2.2kΩ 1/16W J	1	
	R725	NRSA6AJ-393W	MG RESISTOR	39kΩ 1/16W J	1	
	R726	NRSA6AJ-562W	MG RESISTOR	5.6kΩ 1/16W J	1	
	R727	NRSA6AJ-682W	MG RESISTOR	6.8kΩ 1/16W J	1	
	R728	NRSA6AJ-223W	MG RESISTOR	22kΩ 1/16W J	1	
	R729	NRSA6AJ-393W	MG RESISTOR	39kΩ 1/16W J	1	
	R731	NRSA6AJ-103W	MG RESISTOR	10kΩ 1/16W J	1	
	R733	NRSA6AJ-122W	MG RESISTOR	1.2kΩ 1/16W J	1	
	R734	NRSA6AJ-473W	MG RESISTOR	47kΩ 1/16W J	1	
	R735	NRSA6AJ-392W	MG RESISTOR	3.9kΩ 1/16W J	1	
	R736	NRSA6AJ-392W	MG RESISTOR	3.9kΩ 1/16W J	1	
	R741	NRSA6AJ-473W	MG RESISTOR	47kΩ 1/16W J	1	
	R743	NRSA6AJ-473W	MG RESISTOR	47kΩ 1/16W J	1	
	R745	NRSA6AJ-473W	MG RESISTOR	47kΩ 1/16W J	1	
	R748	NRSA6AJ-473W	MG RESISTOR	47kΩ 1/16W J	1	
	R749	NRSA6AJ-103W	MG RESISTOR	10kΩ 1/16W J	1	B,C,G
	R750	NRSA6AJ-103W	MG RESISTOR	10kΩ 1/16W J	1	A,D,E,F
	R753	NRSA6AJ-473W	MG RESISTOR	47kΩ 1/16W J	1	
	R754	NRSA6AJ-473W	MG RESISTOR	47kΩ 1/16W J	1	
	R755	NRSA6AJ-473W	MG RESISTOR	47kΩ 1/16W J	1	
	R756	NRSA6AJ-0R0W	MG RESISTOR	0Ω 1/16W J	1	
	R758	NRSA6AJ-103W	MG RESISTOR	10kΩ 1/16W J	1	
	R759	NRSA6AJ-102W	MG RESISTOR	1kΩ 1/16W J	1	A
	R761	NRSA6AJ-392W	MG RESISTOR	3.9kΩ 1/16W J	1	
	R762	NRSA6AJ-0R0W	MG RESISTOR	0Ω 1/16W J	1	A
	R763	NRSA6AJ-472W	MG RESISTOR	4.7kΩ 1/16W J	1	A
	R764	NRSA6AJ-472W	MG RESISTOR	4.7kΩ 1/16W J	1	A
	R765	NRSA6AJ-102W	MG RESISTOR	1kΩ 1/16W J	1	A
	R767	NRSA6AJ-102W	MG RESISTOR	1kΩ 1/16W J	1	
	R771	NRSA6AJ-271W	MG RESISTOR	270Ω 1/16W J	1	D,E,F,G
	R772	NRSA6AJ-271W	MG RESISTOR	270Ω 1/16W J	1	D,E,F,G
	R781	NRSA6AJ-473W	MG RESISTOR	47kΩ 1/16W J	1	
	R782	NRSA6AJ-222W	MG RESISTOR	2.2kΩ 1/16W J	1	
	R783	NRSA6AJ-102W	MG RESISTOR	1kΩ 1/16W J	1	
	R784	NRSA6AJ-0R0W	MG RESISTOR	0Ω 1/16W J	1	
	R786	NRSA63J-153X	MG RESISTOR	15kΩ 1/16W J	1	
	R790	NRSA6AJ-223W	MG RESISTOR	22kΩ 1/16W J	1	A,B,C,D,E,F
	R791	NRSA6AJ-222W	MG RESISTOR	2.2kΩ 1/16W J	1	A,B,C,D,E,F
	R792	NRSA6AJ-102W	MG RESISTOR	1kΩ 1/16W J	1	
	R793	NRSA6AJ-102W	MG RESISTOR	1kΩ 1/16W J	1	
	R796	NRSA6AJ-123W	MG RESISTOR	12kΩ 1/16W J	1	
	R797	NRSA6AJ-104W	MG RESISTOR	100kΩ 1/16W J	1	
	R798	NRSA6AJ-474W	MG RESISTOR	470kΩ 1/16W J	1	
	R801	NRSA6AJ-392W	MG RESISTOR	3.9kΩ 1/16W J	1	A
	R803	NRSA6AJ-682W	MG RESISTOR	6.8kΩ 1/16W J	1	A
	R804	NRSA6AJ-101W	MG RESISTOR	100Ω 1/16W J	1	A
	R805	NRSA6AJ-473W	MG RESISTOR	47kΩ 1/16W J	1	A
	R806	NRSA6AJ-104W	MG RESISTOR	100kΩ 1/16W J	1	A
	R807	NRSA6AJ-101W	MG RESISTOR	100Ω 1/16W J	1	A
	R808	NRSA6AJ-473W	MG RESISTOR	47kΩ 1/16W J	1	A
	R809	NRSA6AJ-682W	MG RESISTOR	6.8kΩ 1/16W J	1	A
	R810	NRSA6AJ-104W	MG RESISTOR	100kΩ 1/16W J	1	A
	R811	NRSA6AJ-104W	MG RESISTOR	100kΩ 1/16W J	1	A
	R812	NRSA6AJ-392W	MG RESISTOR	3.9kΩ 1/16W J	1	A
	R814	NRSA6AJ-0R0W	MG RESISTOR	0Ω 1/16W J	1	A
	R851	NRSA63J-472X	MG RESISTOR	4.7kΩ 1/16W J	1	B,C
	R852	NRSA63J-473X	MG RESISTOR	47kΩ 1/16W J	1	B,C
	R853	QRE142J-102X	C RESISTOR	1kΩ 1/4W J	1	B,C
	R881	NRSA6AJ-473W	MG RESISTOR	47kΩ 1/16W J	1	
	R882	NRSA63J-472X	MG RESISTOR	4.7kΩ 1/16W J	1	
	R901	QRE142J-102X	C RESISTOR	1kΩ 1/4W J	1	
	R902	NRSA02J-912X	MG RESISTOR	9.1kΩ 1/10W J	1	
	R903	NRSA02J-472X	MG RESISTOR	4.7kΩ 1/10W J	1	
	R921	NRSA63J-0R0X	MG RESISTOR	0Ω 1/10W J	1	

MODEL	MARK	MODEL	MARK	MODEL	MARK	MODEL	MARK
KW-XR810J	A	KW-XR816U	B	KW-XR816UH	C	KW-XR811E	D
KW-XR811EY	E	KW-XR811EU	F	KW-XR817EE	G		

Safe	Symbol No.	Parts No.	Parts Name	Description	QTY	Local
	R922	NRSA6AJ-0R0W	MG RESISTOR	0Ω 1/16W J	1	
	R923	NRSA6AJ-0R0W	MG RESISTOR	0Ω 1/16W J	1	
	R924	NRS125J-390X	MG RESISTOR	39Ω 1/2W J	1	
	R925	NRS125J-390X	MG RESISTOR	39Ω 1/2W J	1	
	R930	NRSA6AJ-103W	MG RESISTOR	10kΩ 1/16W J	1	
	R931	NRSA6AJ-392W	MG RESISTOR	3.9kΩ 1/16W J	1	
	R932	NRSA63J-394X	MG RESISTOR	390kΩ 1/16W J	1	
	R933	NRSA6AJ-681W	MG RESISTOR	680Ω 1/16W J	1	
	R935	NRSA6AJ-223W	MG RESISTOR	22kΩ 1/16W J	1	
	R936	NRSA6AD-153W	MG RESISTOR	15kΩ 1/16W D	1	
	R937	NRSA6AD-823W	MG RESISTOR	82kΩ 1/16W D	1	
	R940	NRSA6AJ-103W	MG RESISTOR	10kΩ 1/16W J	1	
	R941	NRSA6AJ-392W	MG RESISTOR	3.9kΩ 1/16W J	1	
	R942	NRSA63J-394X	MG RESISTOR	390kΩ 1/16W J	1	
	R943	NRSA6AJ-681W	MG RESISTOR	680Ω 1/16W J	1	
	R945	NRSA6AJ-223W	MG RESISTOR	22kΩ 1/16W J	1	
	R946	NRSA6AD-153W	MG RESISTOR	15kΩ 1/16W D	1	
	R947	NRSA6AD-823W	MG RESISTOR	82kΩ 1/16W D	1	
	R951	NRSA6AJ-103W	MG RESISTOR	10kΩ 1/16W J	1	
	R952	NRSA6AJ-103W	MG RESISTOR	10kΩ 1/16W J	1	
	R971	NRS181J-332X	MG RESISTOR	3.3kΩ 1/8W J	1	
	R976	NRSA02J-513X	MG RESISTOR	51kΩ 1/10W J	1	
	R977	NRSA02J-153X	MG RESISTOR	15kΩ 1/10W J	1	
	R998	NRSA6AJ-0R0W	MG RESISTOR	0Ω 1/16W J	1	
	R999	NRSA63J-0R0X	MG RESISTOR	0Ω 1/10W J	1	
	RA521	NRZ0034-330W	NET RESISTOR	33Ω 1/32W J x4	1	
	RA522	NRZ0034-330W	NET RESISTOR	33Ω 1/32W J x4	1	
	L1	NQL093K-R47X	P COIL	0.47uH K	1	
	L2	NQL093K-1R8X	P COIL	1.8uH K	1	
	L3	NQL093K-R22X	P COIL	0.22uH K	1	
	L4	QQR1872-001	RF COIL		1	
	L5	QQL244J-561Z	COIL	560uH J	1	
	L6	QQL244J-561Z	COIL	560uH J	1	
	L7	QQL244K-4R7Z	COIL	4.7uH K	1	
	L8	QQL244K-4R7Z	COIL	4.7uH K	1	
	L9	NQL093K-R47X	P COIL	0.47uH K	1	
	L472	NQR0536-001X	CHOKE COIL		1	
	L521	NQL093K-1R8X	P COIL	1.8uH K	1	
	L701	QQL244K-4R7Z	COIL	4.7uH K	1	
	L702	QQL244K-4R7Z	COIL	4.7uH K	1	
	L703	QQL244J-470Z	COIL	47uH J	1	
	L901	QQR0703-001	CHOKE COIL		1	
	L901	or QQR1852-001	CHOKE COIL		1	
	L931	NQLC8CM-220X	COIL	22uH M	1	
	L932	NQLH25M-4R7X	COIL	4.7uH M	1	
	L933	NQLH25M-4R7X	COIL	4.7uH M	1	
	L941	NQLC8CM-220X	COIL	22uH M	1	
	CN202	QGA2001C1-02	CONNECTOR	W-B (1-2)	1	
	CN472	QGA2001C1-05	CONNECTOR	W-B (1-5)	1	
	CN501	QGB2027MD-26	CONNECTOR	B-B (1-26)	1	
	CN701	QGB1004K1-24	CONNECTOR	B-B (1-24)	1	
	CN702	QNS0283-001	3.5 JACK		1	A,B,C,D,E,F
	CN901	QNZ0607-001	CAR CONNECTOR		1	
	F971	NRSA63J-0R0X	MG RESISTOR	0Ω 1/10W J	1	
	J1	QNB0190-001	ANT TERMINAL		1	
	J1	or QNB0348-001	ANT TERMINAL		1	
	J321	QNN0837-001	PIN JACK		1	
	J801	QNZ0095-001	CONNECTOR		1	A
	K581	NQR0022-005X	FERRITE BEADS		1	
	K703	NRSA02J-0R0X	MG RESISTOR	0Ω 1/10W J	1	
	K704	NRSA02J-0R0X	MG RESISTOR	0Ω 1/10W J	1	
	K705	NRSA02J-0R0X	MG RESISTOR	0Ω 1/10W J	1	
	PP3	QZW0010-001	STYLE PIN		1	
	PP4	QZW0010-001	STYLE PIN		1	
	PP6	QZW0010-001	STYLE PIN		1	
	X11	QAX0952-001Z	CRYSTAL		1	
	X71	QAX0954-001Z	CRYSTAL		1	D,E,F,G
	X521	QAX0714-001Z	C RESONATOR	16.000MHz	1	
	X701	QAX0916-001Z	CRYSTAL		1	
	X702	QAX0953-001	CRYSTAL		1	

CD mechanism assembly

Block No.MBMM

FLM-CD5-1D

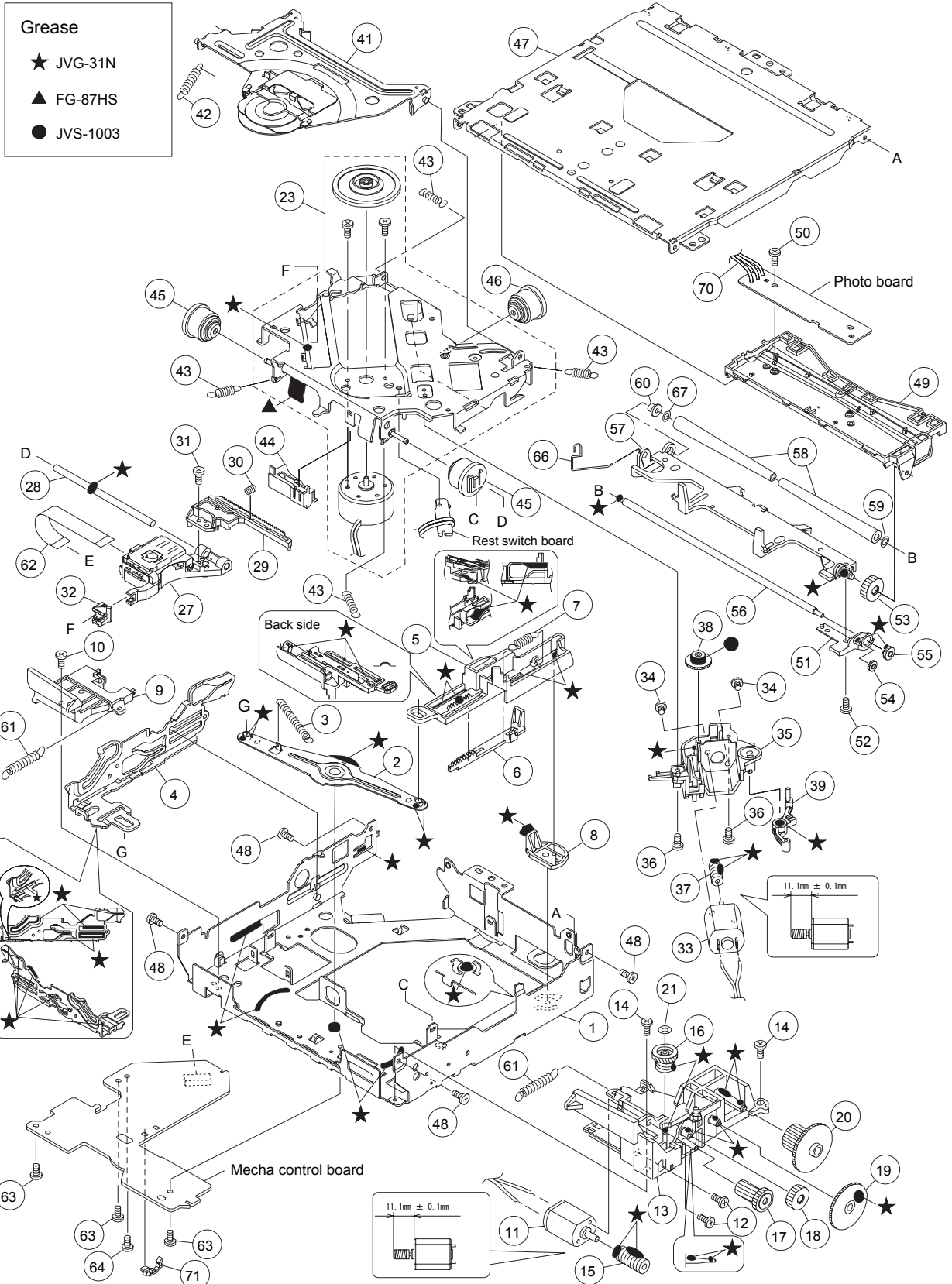

The parts without symbol number are not service.

MODEL	MARK	MODEL	MARK	MODEL	MARK	MODEL	MARK
KW-XR810J	A	KW-XR816U	B	KW-XR816UH	C	KW-XR811E	D
KW-XR811EY	E	KW-XR811EU	F	KW-XR817EE	G		

Safe	Symbol No.	Parts No.	Parts Name	Description	QTY	Local
FLM-CD5-1D CD mechanism <MBMM>						
	1	LV11256-001A	MECHA FRAME		1	A,B,C,D,E,F,G
	2	LV36800-002A	LINK ARM		1	A,B,C,D,E,F,G
	3	LV44658-001A	LINK SPRING		1	A,B,C,D,E,F,G
	4	LV22300-002A	SLIDE CAM (L)		1	A,B,C,D,E,F,G
	5	LV22298-002A	SLIDE CAM(R)		1	A,B,C,D,E,F,G
	6	LV36802-001A	LOAD RACK		1	A,B,C,D,E,F,G
	7	LV44552-001A	RETURN SPRING		1	A,B,C,D,E,F,G
	8	LV36803-002A	F LOCK LEVER		1	A,B,C,D,E,F,G
	9	LV36804-002A	CAM COVER		1	A,B,C,D,E,F,G
	10	VKZ4539-054	MINI SCREW		1	A,B,C,D,E,F,G
	11	QAR0373-002	MOTOR		1	A,B,C,D,E,F,G
	12	QYSPSPT2025MA	SCREW	M2 x 2.5mm	2	A,B,C,D,E,F,G
	13	LV36903-003A	L M BASE ASSY		1	A,B,C,D,E,F,G
	14	VKZ4539-054	MINI SCREW		2	A,B,C,D,E,F,G
	15	LV36806-001A	L WORM GEAR		1	A,B,C,D,E,F,G
	16	LV36805-002A	M WHEEL GEAR		1	A,B,C,D,E,F,G
	17	LV36807-001A	A WHEEL GEAR		1	A,B,C,D,E,F,G
	18	LV36808-001A	R ACT GEAR(1)		1	A,B,C,D,E,F,G
	19	LV36809-001A	LOAD ACT GEAR		1	A,B,C,D,E,F,G
	20	LV36810-001A	LOADING GEAR		1	A,B,C,D,E,F,G
	21	QYWDL1230250	SLIT WASHER	3mm/1.2mm x 0.25mm	1	A,B,C,D,E,F,G
	23	CM-FLMCD1D	SPINDLE MOTOR ASSY		1	A,B,C,D,E,F,G
	27	QAL1226-001	PICK UP		1	A,B,C,D,E,F,G
	28	LV44555-001A	MAIN SHAFT		1	A,B,C,D,E,F,G
	29	LV36799-001A	RACK PLATE		1	A,B,C,D,E,F,G
	30	LV45227-001A	RACK SPRING		1	A,B,C,D,E,F,G
	31	QYSPSGT1745ZA	TAP SCREW	M1.7 x 4.5mm	1	A,B,C,D,E,F,G
	32	LV36813-201A	SUB GUIDE CAP		1	A,B,C,D,E,F,G
	33	QAR0144-003	MOTOR	2.0V DC	1	A,B,C,D,E,F,G
	34	QYSPSPT2025MA	SCREW	M2 x 2.5mm	2	A,B,C,D,E,F,G
	35	LV22296-001A	F MOTOR HOLDER		1	A,B,C,D,E,F,G
	36	VKZ4539-054	MINI SCREW		2	A,B,C,D,E,F,G
	37	LV36814-001A	F WORM GEAR		1	A,B,C,D,E,F,G
	38	LV36815-002A	F WHEEL GEAR		1	A,B,C,D,E,F,G
	39	LV36816-001A	TRIGGER ARM		1	A,B,C,D,E,F,G
	41	LV37326-003A	CLAMPER ASSY		1	A,B,C,D,E,F,G
	42	LV44557-002A	CLAMPER SPRING		1	A,B,C,D,E,F,G
	43	LV44558-001A	SUS SPRING		4	A,B,C,D,E,F,G
	44	LV36820-001A	WIRE HOLDER		1	A,B,C,D,E,F,G
	45	LV36904-001A	DAMPER		2	A,B,C,D,E,F,G
	46	LV37061-001A	DAMPER		1	A,B,C,D,E,F,G
	47	LV11260-003A	TOP COVER		1	A,B,C,D,E,F,G
	48	VKZ4539-054	MINI SCREW		4	A,B,C,D,E,F,G
	49	LV11264-003A	DISC PLATE		1	A,B,C,D,E,F,G
	50	LV44586-001A	SPECIAL SCREW		1	A,B,C,D,E,F,G
	51	LV36801-002A	GEAR HOLDER		1	A,B,C,D,E,F,G
	52	VKZ4539-054	MINI SCREW		1	A,B,C,D,E,F,G
	53	LV36821-201A	R ACT GEAR(2)		1	A,B,C,D,E,F,G
	54	LV36822-201A	R ACT GEAR(3)		1	A,B,C,D,E,F,G
	55	LV36823-201A	ROLLER GEAR		1	A,B,C,D,E,F,G
	56	LV44559-003A	ROLLER SHAFT		1	A,B,C,D,E,F,G
	57	LV22744-001A	R HOLDER ASSY 2		1	A,B,C,D,E,F,G
	58	LV44560-001A	ROLLER		2	A,B,C,D,E,F,G
	59	LV44590-001A	WASHER		1	A,B,C,D,E,F,G
	60	LV45268-001A	ROLLER COLLAR 2		1	A,B,C,D,E,F,G
	61	LV44562-002A	ROLLER SPRING		2	A,B,C,D,E,F,G
	62	QAL0817-003	FPC		1	A,B,C,D,E,F,G
	63	VKZ4539-054	MINI SCREW		3	A,B,C,D,E,F,G
	64	VKZ4539-054	MINI SCREW		1	A,B,C,D,E,F,G
	66	LV45269-001A	R HOLDER ROD		1	A,B,C,D,E,F,G
	67	LV45270-001A	WASHER 2		1	A,B,C,D,E,F,G
	70	WJS0085-001A-E	E-FL/RB WIRE		1	A,B,C,D,E,F,G
	71	LV34916-002A	WIRE CLAMP		1	A,B,C,D,E,F,G
Switch board <02>						
	IC601	PCA9624PW-X	IC		1	
	IC602	S-80824CNNB-G-W	IC		1	
	IC602	or IC-PST3424U-X	IC		1	
	IC661	JES187F	IC(MCU)		1	
	IC681	KSM-2003TN2M	IR DETECT UNIT		1	
	Q601	2SC1623A/5-6/-X	TRANSISTOR		1	
	Q601	or 2SC3928A/QR/-X	TRANSISTOR		1	
	Q602	2SA812A/5-6/-X	TRANSISTOR		1	
	Q602	or ISA1530AC1/QR/X	TRANSISTOR		1	
	Q603	2SA812A/5-6/-X	TRANSISTOR		1	
	Q603	or ISA1530AC1/QR/X	TRANSISTOR		1	
	D601	NSSM065T-X	LED		1	
	D602	NSSM065T-X	LED		1	
	D603	NSSM065T-X	LED		1	
	D604	NSSM065T-X	LED		1	
	D605	NSSM065T-X	LED		1	
	D609	NSSM065T-X	LED		1	
	D610	NSSM065T-X	LED		1	
	D618	RKZ5.6B2KG-X	Z DIODE		1	
	D618	or MA8056/M/-X	Z DIODE		1	
	D620	LHQ974/LM/-X	LED		1	
	D621	LHQ974/LM/-X	LED		1	
	D630	MC2838-X	DIODE		1	
	D630	or MA152WK-X	SI DIODE		1	
	D640	RKZ5.1B2KG-X	Z DIODE		1	

MODEL	MARK	MODEL	MARK	MODEL	MARK	MODEL	MARK
KW-XR810J	A	KW-XR816U	B	KW-XR816UH	C	KW-XR811E	D
KW-XR811EY	E	KW-XR811EU	F	KW-XR817EE	G		

Safe	Symbol No.	Parts No.	Parts Name	Description	QTY	Local
	D640	or MA8051/M-X	Z DIODE		1	
	D641	RKZ5.1B2KG-X	Z DIODE		1	
	D641	or MA8051/M-X	Z DIODE		1	
	D651	HSU119-X	SI DIODE		1	
	D651	or MA111-X	SI DIODE		1	
	D693	MA8051/M-X	Z DIODE		1	
	C601	NCB31CK-104X	C CAPACITOR	0.1uF 16V K	1	
	C602	NCB31CK-105X	C CAPACITOR	1uF 16V K	1	
	C604	NBE21CM-106X	TA E CAPACITOR	10uF 16V M	1	
	C607	NCB31EK-104X	C CAPACITOR	0.1uF 25V K	1	
	C608	NCB31EK-104X	C CAPACITOR	0.1uF 25V K	1	
	C640	NCJ11EK-106X-R	C CAPACITOR	10uF 25V	1	
	C641	NCB31EK-103X	C CAPACITOR	0.01uF 25V K	1	
	C642	NCB20JK-475X	C CAPACITOR	4.7uF 6.3V K	1	
	C646	NCB20JK-475X	C CAPACITOR	4.7uF 6.3V K	1	
	C647	NCJ31CK-105X-A	C CAPACITOR	1uF 16V K	1	
	C648	NCJ31CK-105X-A	C CAPACITOR	1uF 16V K	1	
	C649	NCJ31CK-105X-A	C CAPACITOR	1uF 16V K	1	
	C650	NCJ31CK-105X-A	C CAPACITOR	1uF 16V K	1	
	C651	NCB11EM-105X	C CAPACITOR	1uF 25V M	1	
	C652	NCJ31CK-105X-A	C CAPACITOR	1uF 16V K	1	
	C653	NCB11EM-105X	C CAPACITOR	1uF 25V M	1	
	C654	NCJ31CK-105X-A	C CAPACITOR	1uF 16V K	1	
	C655	NCJ31CK-105X-A	C CAPACITOR	1uF 16V K	1	
	C656	NCJ31CK-105X-A	C CAPACITOR	1uF 16V K	1	
	C657	NCJ31CK-105X-A	C CAPACITOR	1uF 16V K	1	
	C658	NCJ31CK-105X-A	C CAPACITOR	1uF 16V K	1	
	C659	NCB31CK-104X	C CAPACITOR	0.1uF 16V K	1	
	C661	NCB31EK-473X	C CAPACITOR	0.047uF 25V K	1	
	C662	NCB20JK-106X	C CAPACITOR	10uF 6.3V K	1	
	C663	NCB31EK-473X	C CAPACITOR	0.047uF 25V K	1	
	C667	NBE20JM-106X	TA E CAPACITOR	10uF 6.3V M	1	
	C669	NCB31EK-473X	C CAPACITOR	0.047uF 25V K	1	
	C670	NCB31CK-104X	C CAPACITOR	0.1uF 16V K	1	
	C671	NCB31EK-473X	C CAPACITOR	0.047uF 25V K	1	
	C682	NCB31EK-104X	C CAPACITOR	0.1uF 25V K	1	
	R601	NRSA63J-101X	MG RESISTOR	100Ω 1/16W J	1	
	R602	NRSA63J-101X	MG RESISTOR	100Ω 1/16W J	1	
	R603	NRSA63J-0R0X	MG RESISTOR	0Ω 1/10W J	1	
	R604	NRSA63J-102X	MG RESISTOR	1kΩ 1/16W J	1	
	R605	NRSA63J-0R0X	MG RESISTOR	0Ω 1/10W J	1	
	R607	NRS181J-431X	MG RESISTOR	430Ω 1/8W J	1	
	R608	NRS181J-431X	MG RESISTOR	430Ω 1/8W J	1	
	R609	NRS181J-821X	MG RESISTOR	820Ω 1/8W J	1	
	R610	NRS181J-471X	MG RESISTOR	470Ω 1/8W J	1	
	R611	NRS181J-471X	MG RESISTOR	470Ω 1/8W J	1	
	R612	NRS181J-751X	MG RESISTOR	750Ω 1/8W J	1	
	R613	NRS181J-471X	MG RESISTOR	470Ω 1/8W J	1	
	R614	NRS181J-471X	MG RESISTOR	470Ω 1/8W J	1	
	R615	NRS181J-751X	MG RESISTOR	750Ω 1/8W J	1	
	R618	NRS181J-271X	MG RESISTOR	270Ω 1/8W J	1	
	R619	NRS181J-271X	MG RESISTOR	270Ω 1/8W J	1	
	R620	NRS181J-621X	MG RESISTOR	620Ω 1/8W J	1	
	R621	NRSA63J-821X	MG RESISTOR	820Ω 1/16W J	1	
	R622	NRSA63J-821X	MG RESISTOR	820Ω 1/16W J	1	
	R623	NRSA63J-122X	MG RESISTOR	1.2kΩ 1/16W J	1	
	R624	NRSA63J-182X	MG RESISTOR	1.8kΩ 1/16W J	1	
	R625	NRSA63J-272X	MG RESISTOR	2.7kΩ 1/16W J	1	
	R626	NRSA63J-821X	MG RESISTOR	820Ω 1/16W J	1	
	R627	NRSA63J-821X	MG RESISTOR	820Ω 1/16W J	1	
	R628	NRSA63J-122X	MG RESISTOR	1.2kΩ 1/16W J	1	
	R629	NRSA63J-182X	MG RESISTOR	1.8kΩ 1/16W J	1	
	R630	NRSA63J-272X	MG RESISTOR	2.7kΩ 1/16W J	1	
	R631	NRSA63J-821X	MG RESISTOR	820Ω 1/16W J	1	
	R632	NRSA63J-821X	MG RESISTOR	820Ω 1/16W J	1	
	R633	NRSA63J-122X	MG RESISTOR	1.2kΩ 1/16W J	1	
	R634	NRSA63J-182X	MG RESISTOR	1.8kΩ 1/16W J	1	
	R635	NRSA63J-272X	MG RESISTOR	2.7kΩ 1/16W J	1	
	R636	NRSA63J-0R0X	MG RESISTOR	0Ω 1/10W J	1	
	R641	NRSA63J-153X	MG RESISTOR	15kΩ 1/16W J	1	
	R642	NRSA63J-153X	MG RESISTOR	15kΩ 1/16W J	1	
	R645	NRSA63J-101X	MG RESISTOR	100Ω 1/16W J	1	
	R646	NRSA63J-473X	MG RESISTOR	47kΩ 1/16W J	1	
	R647	NRSA63J-222X	MG RESISTOR	2.2kΩ 1/16W J	1	
	R649	NRS181J-471X	MG RESISTOR	470Ω 1/8W J	1	
	R650	NRSA63J-472X	MG RESISTOR	4.7kΩ 1/16W J	1	
	R651	NRSA63J-472X	MG RESISTOR	4.7kΩ 1/16W J	1	
	R652	NRSA63J-681X	MG RESISTOR	680Ω 1/16W J	1	
	R653	NRSA63J-681X	MG RESISTOR	680Ω 1/16W J	1	
	R654	NRSA63J-102X	MG RESISTOR	1kΩ 1/16W J	1	
	R655	NRSA63J-102X	MG RESISTOR	1kΩ 1/16W J	1	
	R656	NRSA63J-103X	MG RESISTOR	10kΩ 1/16W J	1	
	R657	NRSA63J-473X	MG RESISTOR	47kΩ 1/16W J	1	
	R658	NRSA63J-473X	MG RESISTOR	47kΩ 1/16W J	1	
	R660	NRSA63J-103X	MG RESISTOR	10kΩ 1/16W J	1	
	R661	NRSA63J-222X	MG RESISTOR	2.2kΩ 1/16W J	1	
	R662	NRSA63J-680X	MG RESISTOR	68Ω 1/16W J	1	
	R664	NRSA63J-103X	MG RESISTOR	10kΩ 1/16W J	1	
	R665	NRSA63J-331X	MG RESISTOR	330Ω 1/16W J	1	
	R666	NRS181J-103X	MG RESISTOR	10kΩ 1/8W J	1	
	R668	NRSA63J-153X	MG RESISTOR	15kΩ 1/16W J	1	
	R669	NRSA63J-103X	MG RESISTOR	10kΩ 1/16W J	1	

MODEL	MARK	MODEL	MARK	MODEL	MARK	MODEL	MARK
KW-XR810J	A	KW-XR816U	B	KW-XR816UH	C	KW-XR811E	D
KW-XR811EY	E	KW-XR811EU	F	KW-XR817EE	G		

Safe	Symbol No.	Parts No.	Parts Name	Description	QTY	Local
	R670	NRSA63J-103X	MG RESISTOR	10kΩ 1/16W J	1	
	R672	NRSA63J-331X	MG RESISTOR	330Ω 1/16W J	1	
	R673	NRSA63J-331X	MG RESISTOR	330Ω 1/16W J	1	
	R675	NRSA63J-331X	MG RESISTOR	330Ω 1/16W J	1	
	R676	NRS181J-331X	MG RESISTOR	330Ω 1/8W J	1	
	R677	NRSA63J-0R0X	MG RESISTOR	0Ω 1/10W J	1	
	R680	NRSA63J-103X	MG RESISTOR	10kΩ 1/16W J	1	
	R681	NRSA63J-392X	MG RESISTOR	3.9kΩ 1/16W J	1	
	R682	NRSA63J-103X	MG RESISTOR	10kΩ 1/16W J	1	
	R686	NRSA63J-471X	MG RESISTOR	470Ω 1/16W J	1	
	R687	NRS181J-102X	MG RESISTOR	1kΩ 1/8W J	1	
	R688	NRSA63J-472X	MG RESISTOR	4.7kΩ 1/16W J	1	
	R690	NRSA63J-103X	MG RESISTOR	10kΩ 1/16W J	1	
	R691	NRSA63J-472X	MG RESISTOR	4.7kΩ 1/16W J	1	
	R692	NRSA63J-472X	MG RESISTOR	4.7kΩ 1/16W J	1	
	R693	NRS181J-103X	MG RESISTOR	10kΩ 1/8W J	1	
	R694	NRSA63J-103X	MG RESISTOR	10kΩ 1/16W J	1	
	R695	NRSA63J-473X	MG RESISTOR	47kΩ 1/16W J	1	
	R696	NRSA63J-473X	MG RESISTOR	47kΩ 1/16W J	1	
	R697	NRSA63J-474X	MG RESISTOR	470kΩ 1/16W J	1	
	R698	NRS181J-331X	MG RESISTOR	330Ω 1/8W J	1	
	R699	NCB31HK-472X	C CAPACITOR	4700pF 50V K	1	
	R701	NRS181J-122X	MG RESISTOR	1.2kΩ 1/8W J	1	
	R702	NRS181J-821X	MG RESISTOR	820Ω 1/8W J	1	
	R703	NRS181J-821X	MG RESISTOR	820Ω 1/8W J	1	
	RA661	NRZ0065-472X	MG RESISTOR	4.7kΩ	1	
	RA662	NRZ0065-472X	MG RESISTOR	4.7kΩ	1	
	RA663	NRZ0065-472X	MG RESISTOR	4.7kΩ	1	
	RA664	NRZ0065-331X	NET RESISTOR	330Ω	1	
	RA665	NRZ0065-331X	NET RESISTOR	330Ω	1	
	L603	NQL79GM-470X	COIL	47uH M	1	
	L604	NQR0022-005X	FERRITE BEADS		1	
	L640	NQR0536-001X	CHOKO COIL		1	
	L661	NQL79GM-470X	COIL	47uH M	1	
	L685	NQR0007-002X	FERRITE BEADS		1	
	L686	NQR0007-002X	FERRITE BEADS		1	
	L687	NQR0007-002X	FERRITE BEADS		1	
	CN601	QGB1004J2-24X	CONNECTOR	B-B (1-24)	1	
	CN602	QGF0522F3-33W	CONNECTOR	FFC/FCF (1-33)	1	
	CN603	QNZ0906-001	USB CONNECTOR		1	
	EN601	QSW1280-001	ROTARY ENCODER		1	
	J601	QNS0303-001	3.5 JACK		1	
	S661	NSW0326-001X	TACT SWITCH		1	
	S662	NSW0326-001X	TACT SWITCH		1	
	S663	NSW0326-001X	TACT SWITCH		1	
	S664	NSW0326-001X	TACT SWITCH		1	
	S665	NSW0326-001X	TACT SWITCH		1	
	S666	NSW0326-001X	TACT SWITCH		1	
	S667	NSW0326-001X	TACT SWITCH		1	
	S668	NSW0326-001X	TACT SWITCH		1	
	S669	NSW0326-001X	TACT SWITCH		1	
	S670	NSW0326-001X	TACT SWITCH		1	
	S671	NSW0326-001X	TACT SWITCH		1	
	S672	NSW0326-001X	TACT SWITCH		1	
	S673	NSW0326-001X	TACT SWITCH		1	
	S674	NSW0326-001X	TACT SWITCH		1	
	S675	NSW0326-001X	TACT SWITCH		1	
	S676	NSW0326-001X	TACT SWITCH		1	
	S677	NSW0326-001X	TACT SWITCH		1	
	S691	NSW0326-001X	TACT SWITCH		1	
	X661	NAX0752-001X	C RESONATOR		1	
Module board <03>						
	IC401	TCC8600	IC		1	
	IC402	R1EX24256ASAS-X	IC		1	
	IC441	JVM481J	PROGRAMMED IC		1	
	IC442	M12L1281687TG2T	IC(DIGITAL)		1	
	IC471	74LVC1G3157GW-X	IC		1	
	IC481	MFI341S2162-X	IC		1	
	IC491	NJM2878F4-18-X	IC		1	
	IC601	PCM1780-X	IC		1	
	Q401	RT1N441C-X	TRANSISTOR		1	
	Q401	or UN2213-X	DIGI TRANSISTOR		1	
	D601	RKZ5.1B2KG-X	Z DIODE		1	
	D601	or MA8051/M-X	Z DIODE		1	
	C401	NCB31CK-104X	C CAPACITOR	0.1uF 16V K	1	
	C402	NCB31CK-104X	C CAPACITOR	0.1uF 16V K	1	
	C403	NCB31CK-104X	C CAPACITOR	0.1uF 16V K	1	
	C404	NCB31CK-104X	C CAPACITOR	0.1uF 16V K	1	
	C405	NCB31CK-104X	C CAPACITOR	0.1uF 16V K	1	
	C406	NCBA1CK-104W	C CAPACITOR	0.1uF 16V K	1	
	C407	NDC31HJ-270X	C CAPACITOR	27pF 50V J	1	
	C408	NDC31HJ-330X	C CAPACITOR	33pF 50V J	1	
	C409	NCBA1CK-104W	C CAPACITOR	0.1uF 16V K	1	
	C410	NCB31CK-104X	C CAPACITOR	0.1uF 16V K	1	
	C414	NCBA1CK-104W	C CAPACITOR	0.1uF 16V K	1	
	C415	NCBA1HK-122W	C CAPACITOR	1200pF 50V K	1	
	C416	NCJ30JM-106X-A	C CAPACITOR	10uF 6.3V M	1	
	C417	NDCA1HJ-331W	C CAPACITOR	330pF 50V J	1	
	C418	NCB31AK-154X	C CAPACITOR	0.15uF 10V K	1	
	C419	NCB31CK-104X	C CAPACITOR	0.1uF 16V K	1	
	C420	NCB31CK-104X	C CAPACITOR	0.1uF 16V K	1	

MODEL	MARK	MODEL	MARK	MODEL	MARK	MODEL	MARK
KW-XR810J	A	KW-XR816U	B	KW-XR816UH	C	KW-XR811E	D
KW-XR811EY	E	KW-XR811EU	F	KW-XR817EE	G		

Safe	Symbol No.	Parts No.	Parts Name	Description	QTY	Local
	C421	NCBA1CK-104W	C CAPACITOR	0.1uF 16V K	1	
	C422	NCBA1CK-104W	C CAPACITOR	0.1uF 16V K	1	
	C423	NCBA1CK-104W	C CAPACITOR	0.1uF 16V K	1	
	C424	NCBA1CK-104W	C CAPACITOR	0.1uF 16V K	1	
	C425	NCB31CK-104X	C CAPACITOR	0.1uF 16V K	1	
	C426	NDCA1HJ-200W	C CAPACITOR	20pF 50V J	1	
	C430	NQR0450-001X	EMI FILTER	0.022uF 50V M	1	
	C441	NCBA1CK-104W	C CAPACITOR	0.1uF 16V K	1	
	C442	NBE20JM-226X	TA E CAPACITOR	22uF 6.3V M	1	
	C443	NBE20JM-226X	TA E CAPACITOR	22uF 6.3V M	1	
	C444	NCB31CK-104X	C CAPACITOR	0.1uF 16V K	1	
	C445	NCB31CK-104X	C CAPACITOR	0.1uF 16V K	1	
	C446	NCB31CK-104X	C CAPACITOR	0.1uF 16V K	1	
	C447	NCB31CK-104X	C CAPACITOR	0.1uF 16V K	1	
	C448	NCB31CK-104X	C CAPACITOR	0.1uF 16V K	1	
	C449	NCB31CK-104X	C CAPACITOR	0.1uF 16V K	1	
	C450	NCB31CK-104X	C CAPACITOR	0.1uF 16V K	1	
	C451	NDCA1HJ-221W	C CAPACITOR	220pF 50V J	1	
	C452	NDCA1HJ-221W	C CAPACITOR	220pF 50V J	1	
	C453	NDCA1HJ-221W	C CAPACITOR	220pF 50V J	1	
	C471	NCBA1CK-104W	C CAPACITOR	0.1uF 16V K	1	
	C481	NCB31CK-104X	C CAPACITOR	0.1uF 16V K	1	
	C482	NCBA1CK-104W	C CAPACITOR	0.1uF 16V K	1	
	C491	NBE41AM-476X	TA E CAPACITOR	47uF 10V M	1	
	C492	NCB20JK-106X	C CAPACITOR	10uF 6.3V K	1	
	C493	NCB31CK-104X	C CAPACITOR	0.1uF 16V K	1	
	C494	NCBA1CK-104W	C CAPACITOR	0.1uF 16V K	1	
	C495	NBE20JM-226X	TA E CAPACITOR	22uF 6.3V M	1	
	C497	NDC31HJ-331X	C CAPACITOR	330pF 50V J	1	
	C601	NBE41AM-476X	TA E CAPACITOR	47uF 10V M	1	
	C602	NCBA1CK-123W	C CAPACITOR	0.012uF 16V K	1	
	C603	NCBA1CK-104W	C CAPACITOR	0.1uF 16V K	1	
	C604	NBE41AM-476X	TA E CAPACITOR	47uF 10V M	1	
	C605	NDCA1HJ-101W	C CAPACITOR	100pF 50V J	1	
	C606	NDCA1HJ-101W	C CAPACITOR	100pF 50V J	1	
	R401	NRSA6AJ-470W	MG RESISTOR	47Ω 1/16W J	1	
	R402	NRSA6AJ-470W	MG RESISTOR	47Ω 1/16W J	1	
	R403	NRSA6AJ-470W	MG RESISTOR	47Ω 1/16W J	1	
	R404	NRSA6AJ-151W	MG RESISTOR	150Ω 1/16W J	1	
	R405	NRSA6AJ-105W	MG RESISTOR	1MΩ 1/16W J	1	
	R406	NQR0022-005X	FERRITE BEADS		1	
	R407	NQR0286-007X	FERRITE BEADS		1	
	R408	NRSA6AJ-223W	MG RESISTOR	22kΩ 1/16W J	1	
	R409	NRSA6AJ-223W	MG RESISTOR	22kΩ 1/16W J	1	
	R410	NRSA6AJ-472W	MG RESISTOR	4.7kΩ 1/16W J	1	
	R411	NRSA6AJ-330W	MG RESISTOR	33Ω 1/16W J	1	
	R412	NRSA6AJ-330W	MG RESISTOR	33Ω 1/16W J	1	
	R413	NRSA6AJ-330W	MG RESISTOR	33Ω 1/16W J	1	
	R414	NRSA6AJ-330W	MG RESISTOR	33Ω 1/16W J	1	
	R415	NRSA6AJ-102W	MG RESISTOR	1kΩ 1/16W J	1	
	R416	NRSA6AJ-271W	MG RESISTOR	270Ω 1/16W J	1	
	R417	NRSA6AJ-271W	MG RESISTOR	270Ω 1/16W J	1	
	R418	NRSA6AJ-472W	MG RESISTOR	4.7kΩ 1/16W J	1	
	R419	NRSA6AJ-472W	MG RESISTOR	4.7kΩ 1/16W J	1	
	R420	NRSA6AJ-472W	MG RESISTOR	4.7kΩ 1/16W J	1	
	R421	NRSA6AJ-222W	MG RESISTOR	2.2kΩ 1/16W J	1	
	R422	NRSA6AJ-222W	MG RESISTOR	2.2kΩ 1/16W J	1	
	R424	NQR0286-007X	FERRITE BEADS		1	
	R425	NRSA6AJ-102W	MG RESISTOR	1kΩ 1/16W J	1	
	R426	NRSA6AJ-472W	MG RESISTOR	4.7kΩ 1/16W J	1	
	R427	NRSA6AJ-472W	MG RESISTOR	4.7kΩ 1/16W J	1	
	R428	NRSA63J-101X	MG RESISTOR	100Ω 1/16W J	1	
	R429	NRSA6AJ-472W	MG RESISTOR	4.7kΩ 1/16W J	1	
	R430	NRSA6AJ-101W	MG RESISTOR	100Ω 1/16W J	1	
	R431	NRSA6AJ-101W	MG RESISTOR	100Ω 1/16W J	1	
	R432	NRSA6AJ-102W	MG RESISTOR	1kΩ 1/16W J	1	
	R433	NRSA6AJ-102W	MG RESISTOR	1kΩ 1/16W J	1	
	R434	NRSA6AJ-472W	MG RESISTOR	4.7kΩ 1/16W J	1	
	R435	NRSA63J-103X	MG RESISTOR	10kΩ 1/16W J	1	
	R441	NRSA6AJ-0R0W	MG RESISTOR	0Ω 1/16W J	1	
	R443	NRSA63J-472X	MG RESISTOR	4.7kΩ 1/16W J	1	
	R444	NRSA6AJ-473W	MG RESISTOR	47kΩ 1/16W J	1	
	R446	NRSA63J-472X	MG RESISTOR	4.7kΩ 1/16W J	1	
	R447	NRSA6AJ-472W	MG RESISTOR	4.7kΩ 1/16W J	1	
	R448	NRSA6AJ-472W	MG RESISTOR	4.7kΩ 1/16W J	1	
	R449	NRSA6AJ-472W	MG RESISTOR	4.7kΩ 1/16W J	1	
	R450	NRSA6AJ-472W	MG RESISTOR	4.7kΩ 1/16W J	1	
	R451	NQR0286-007X	FERRITE BEADS		1	
	R452	NQR0286-007X	FERRITE BEADS		1	
	R453	NQR0286-007X	FERRITE BEADS		1	
	R454	NQR0286-007X	FERRITE BEADS		1	
	R455	NRSA6AJ-330W	MG RESISTOR	33Ω 1/16W J	1	
	R456	NRSA6AJ-330W	MG RESISTOR	33Ω 1/16W J	1	
	R457	NRSA6AJ-330W	MG RESISTOR	33Ω 1/16W J	1	
	R458	NRSA6AJ-0R0W	MG RESISTOR	0Ω 1/16W J	1	
	R481	NRSA6AJ-473W	MG RESISTOR	47kΩ 1/16W J	1	
	R521	NQR0286-007X	FERRITE BEADS		1	
	R601	NQR0286-007X	FERRITE BEADS		1	
	R602	NQR0286-007X	FERRITE BEADS		1	
	R603	NQR0286-007X	FERRITE BEADS		1	
	R604	NRSA6AJ-220W	MG RESISTOR	22Ω 1/16W J	1	

MODEL	MARK	MODEL	MARK	MODEL	MARK	MODEL	MARK
KW-XR810J	A	KW-XR816U	B	KW-XR816UH	C	KW-XR811E	D
KW-XR811EY	E	KW-XR811EU	F	KW-XR817EE	G		

Safe	Symbol No.	Parts No.	Parts Name	Description	QTY	Local
	R605	NRSA6AJ-220W	MG RESISTOR	22Ω 1/16W J	1	
	R606	NRSA6AJ-220W	MG RESISTOR	22Ω 1/16W J	1	
	R607	NRSA63J-220X	MG RESISTOR	22Ω 1/16W J	1	
	R608	NRS181J-181X	MG RESISTOR	180Ω 1/8W J	1	
	R609	NRS181J-181X	MG RESISTOR	180Ω 1/8W J	1	
	L401	NQL093K-R12X	P COIL	0.12uH K	1	
	L402	NQL093K-R12X	P COIL	0.12uH K	1	
	L403	NRSA02J-0R0X	MG RESISTOR	0Ω 1/10W J	1	
	L404	NQR0022-005X	FERRITE BEADS		1	
	L405	NQR0022-005X	FERRITE BEADS		1	
	L406	NRSA63J-151X	MG RESISTOR	150Ω 1/16W J	1	
	L407	NQR0022-005X	FERRITE BEADS		1	
	L409	NQR0536-001X	CHOCOIL		1	
	L410	NQR0536-001X	CHOCOIL		1	
	L491	NQL79GM-4R7X	COIL	4.7uH M	1	
	L601	NQL79GM-470X	COIL	47uH M	1	
	CN441	QGG2011M1-18X	CONNECTOR	(1-18)	1	
	CN442	QGG2011M1-18X	CONNECTOR	(1-18)	1	
	CN444	QGG2504M5-02	CONNECTOR	(1-2)	1	
	K441	NQR0502-001X	FERRITE BEADS		1	
	K442	NQR0286-007X	FERRITE BEADS		1	
	K443	NQR0286-007X	FERRITE BEADS		1	
	K444	NQR0286-007X	FERRITE BEADS		1	
	K445	NQR0286-007X	FERRITE BEADS		1	
	K446	NQR0286-007X	FERRITE BEADS		1	
	K447	NQR0286-007X	FERRITE BEADS		1	
	K448	NQR0286-007X	FERRITE BEADS		1	
	K449	NQR0286-007X	FERRITE BEADS		1	
	K450	NQR0286-007X	FERRITE BEADS		1	
	K451	NQR0022-005X	FERRITE BEADS		1	
	X401	NAX0975-001X	CRYSTAL		1	
FLM-CD5-1D Mecha control board <04>						
	Q101	2SC3928A/R/-X	TRANSISTOR		1	A,B,C,D,E,F,G
	Q101	or 2SD601A/R/-X	TRANSISTOR		1	A,B,C,D,E,F,G
	Q201	2SC3928A/R/-X	TRANSISTOR		1	A,B,C,D,E,F,G
	Q201	or 2SD601A/R/-X	TRANSISTOR		1	A,B,C,D,E,F,G
	Q301	PS1191RB22/BC/X	PHOTO TRANSISTOR		1	A,B,C,D,E,F,G
	Q302	PS1191RB22/BC/X	PHOTO TRANSISTOR		1	A,B,C,D,E,F,G
	D101	AN1105W21/AB/-X	IR LED		1	A,B,C,D,E,F,G
	D201	AN1105W21/AB/-X	IR LED		1	A,B,C,D,E,F,G
	R101	NRSA02J-391X	MG RESISTOR	390Ω 1/10W J	1	A,B,C,D,E,F,G
	R102	NRSA63J-822X	MG RESISTOR	8.2kΩ 1/16W J	1	A,B,C,D,E,F,G
	R103	NRSA63J-184X	MG RESISTOR	180kΩ 1/16W J	1	A,B,C,D,E,F,G
	R104	NRSA63J-184X	MG RESISTOR	180kΩ 1/16W J	1	A,B,C,D,E,F,G
	R105	NRSA63J-153X	MG RESISTOR	15kΩ 1/16W J	1	A,B,C,D,E,F,G
	R201	NRSA02J-391X	MG RESISTOR	390Ω 1/10W J	1	A,B,C,D,E,F,G
	R202	NRSA63J-822X	MG RESISTOR	8.2kΩ 1/16W J	1	A,B,C,D,E,F,G
	R203	NRSA63J-184X	MG RESISTOR	180kΩ 1/16W J	1	A,B,C,D,E,F,G
	R204	NRSA63J-184X	MG RESISTOR	180kΩ 1/16W J	1	A,B,C,D,E,F,G
	R205	NRSA63J-153X	MG RESISTOR	15kΩ 1/16W J	1	A,B,C,D,E,F,G
	CN101	QGB2027LA-26X	CONNECTOR	B-B (1-26)	1	A,B,C,D,E,F,G
	CN102	QGF0522F3-15W	CONNECTOR	FFC/FPC (1-15)	1	A,B,C,D,E,F,G
	SW1	NSW0291-001X	DETECT SWITCH		1	A,B,C,D,E,F,G

Packing materials and accessories(J,E,EY,EU,EE)

Block No.M3MM

No additional / supplemental order of WARRANTY CARDS are available.

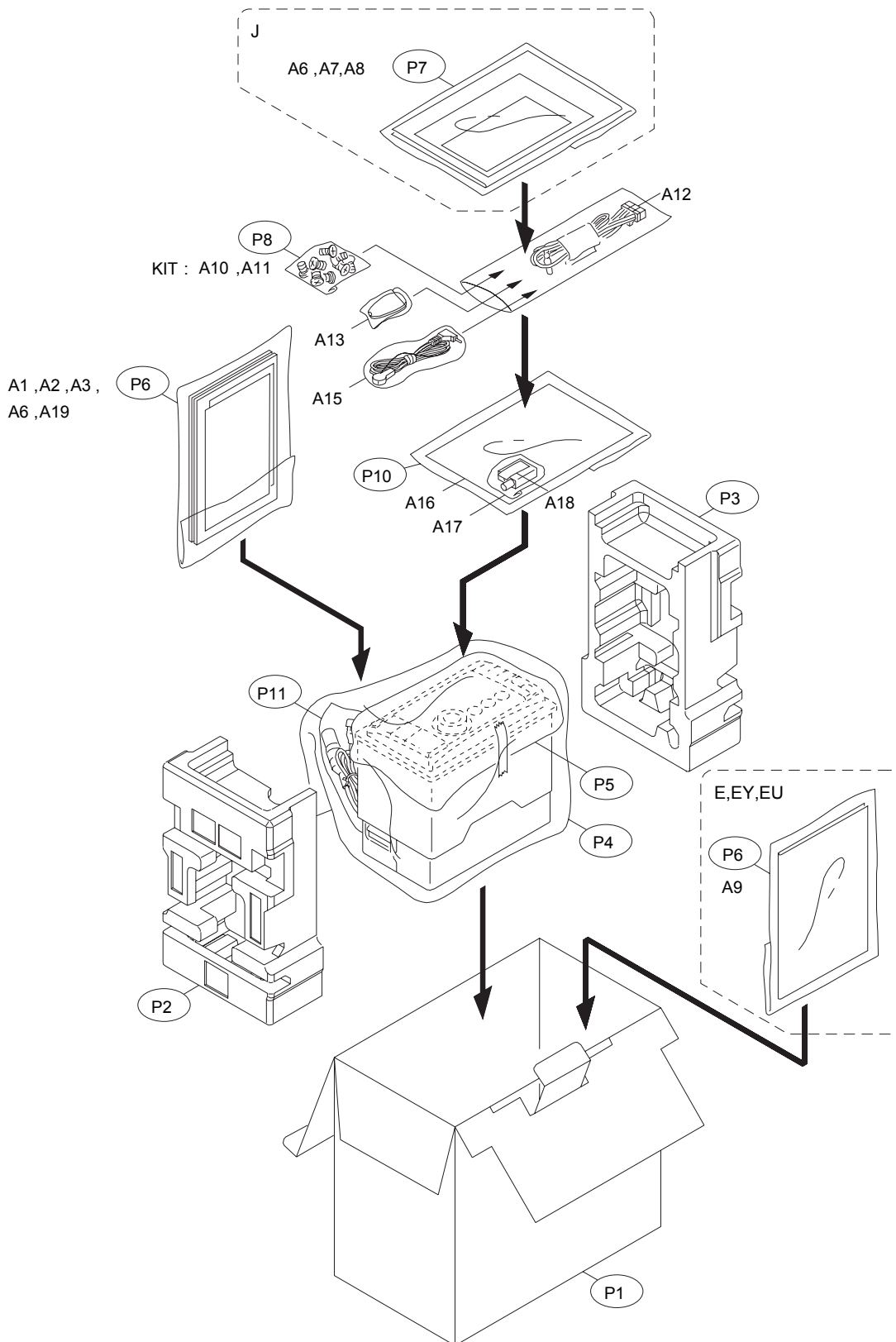

The parts without symbol number are not service.

MODEL	MARK	MODEL	MARK	MODEL	MARK	MODEL	MARK
KW-XR810J	A	KW-XR816U	B	KW-XR816UH	C	KW-XR811E	D
KW-XR811EY	E	KW-XR811EU	F	KW-XR817EE	G		

Safe	Symbol No.	Parts No.	Parts Name	Description	QTY	Local
------	------------	-----------	------------	-------------	-----	-------

Packing and accessories J,E,EY,EU,EE<M3MM>

A1	GET0661-001A	INST BOOK	ENG SPA FRE	1	A
A1	GET0663-001A	INST BOOK	GER	1	D,E
A1	GET0664-001A	INST BOOK	RUS UKR	1	G
A2	GET0663-003A	INST BOOK	ENG FRE	1	D,F
A2	GET0663-007A	INST BOOK	CZE HUN	1	E
A3	GET0661-002A	INSTALL MANUAL	ENG SPA FRE	1	A
A3	GET0663-008A	INSTALL MANUAL	ENG FRE SPA GER DUT ITA POR	1	D
A3	GET0663-011A	INSTALL MANUAL	POL RUS GRE GER CZE HUN	1	E
A3	GET0663-010A	INSTALL MANUAL	ENG FRE SPA TUR RUS PER	1	F
A3	GET0664-002A	INSTALL MANUAL	RUS UKR	1	G
A6	-----	WARRANTY CARD	BT-51018-6	1	A
A6	-----	WARRANTY CARD	BT-54042-1	1	D,E,G
A7	-----	WARRANTY CARD	BT-52008-1	1	A
A8	BT-51044-1	REGISTRATION CARD		1	A
A9	GET0663-002A	INST BOOK	DUT SPA ITA POR	1	D
A9	GET0663-006A	INST BOOK	POL RUS GRE	1	E
A9	GET0663-005A	INST BOOK	SPA RUS TUR PER	1	F
A10	QYSDSP5008ZA	SCREW	M5 x 8mm	8	A,D,E,F,G
A11	QYSSSP5008ZA	SCREW	M5 x 8mm	4	A,D,E,F,G
A12	QAM1143-001	CAR CABLE		1	A
A12	QAM1149-002	CAR CABLE		1	D,E,F,G
A13	RM-RK50C1	REMOCON UNIT		1	A,D,E,F
A15	QAN0096-001	MICROPHONE		1	A,D,E,F,G
A16	GET0617-001C	ADAPTER SHEET		1	A,D,E,F,G
A17	QAU0526-001	RF MODULE		1	A,D,E,F,G
A18	GE40476-001A	BT LABEL		1	F
A19	LVT2148-001B	GOST APPROVAL		1	G
KIT	SRW-MA471	SCREW PARTS KIT	A10 A11	1	A,D,E,F
P1	GE34010-001A	CARTON		1	A
P1	GE34016-001A	CARTON		1	D,E,F
P1	GE34019-001A	CARTON		1	G
P2	GE10280-003A	CUSHION L		1	A,D,E,F,G
P3	GE10281-001A	CUSHION R		1	A,D,E,F,G
P4	QPC03504015PB	POLY BAG	35cm x 40cm	1	A,D,E,F,G
P5	GE40467-003A	NON WOVEN SHEET		1	A,D,E,F,G
P6	FSPG4002-001	POLY BAG		1	A,G
P6	FSPG4002-001	POLY BAG		2	D,E,F
P7	FSPG4002-001	POLY BAG		1	A
P8	QPA00801205	POLY BAG	8cm x 12cm	1	A,D,E,F,G
P10	FSPG4002-001	POLY BAG		1	A,D,E,F,G
P11	QPC01002515	POLY BAG	10cm x 25cm	1	A,D,E,F,G

Packing materials and accessories(U,UH)

Block No.M4MM

No additional / supplemental order of WARRANTY CARDS are available.

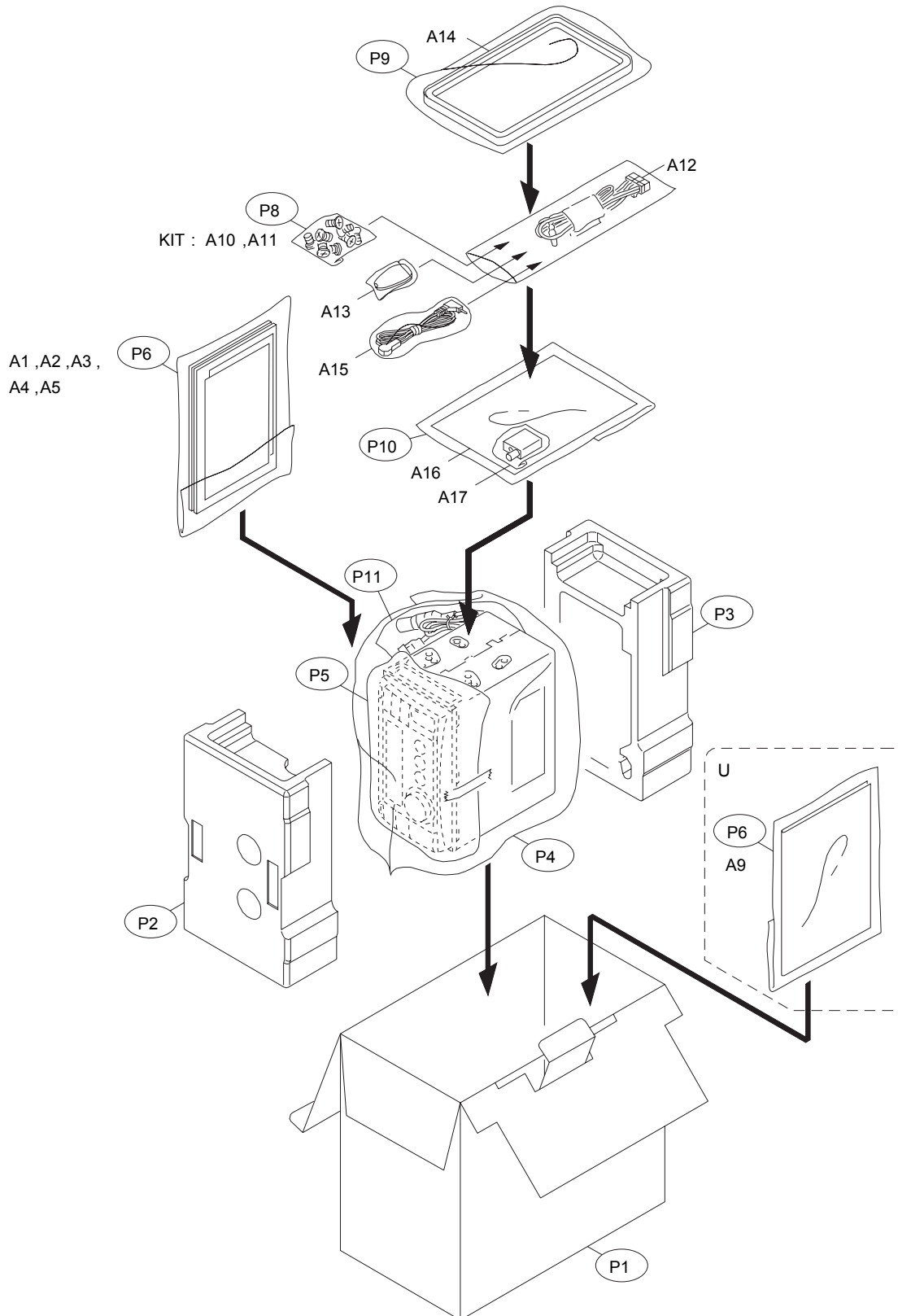

The parts without symbol number are not service.

MODEL	MARK	MODEL	MARK	MODEL	MARK	MODEL	MARK
KW-XR810J	A	KW-XR816U	B	KW-XR816UH	C	KW-XR811E	D
KW-XR811EY	E	KW-XR811EU	F	KW-XR817EE	G		

Safe	Symbol No.	Parts No.	Parts Name	Description	QTY	Local
------	------------	-----------	------------	-------------	-----	-------

Packing and accessories U,UH<M4MM>

A1	GET0662-001A	INST BOOK	ENG THA		1	B,C
A2	GET0662-003A	INST BOOK	RUS		1	B
A3	GET0662-006A	INSTALL MANUAL	ENG THA		1	B,C
A4	GET0662-007A	INSTALL MANUAL	KOR CHI(TAIWAN) ARA PER		1	B
A5	GET0662-008A	INSTALL MANUAL	RUS		1	B
A9	GET0662-002A	INST BOOK	KOR CHI(TAIWAN) ARA PER		1	B
A10	QYSDSP5008ZA	SCREW	M5 x 8mm		8	B,C
A11	QYSSSP5008ZA	SCREW	M5 x 8mm		8	B,C
A12	QAM1146-001	CAR CABLE			1	B,C
A13	RM-RK50M	REMOCON UNIT			1	B,C
A14	GE20224-003A	TRIM PLATE			1	B,C
A15	QAN0096-001	MICROPHONE			1	B,C
A16	GET0617-001C	ADAPTER SHEET			1	B,C
A17	QAU0526-001	RF MODULE			1	B,C
KIT	SRW-KW400J	SCREW PARTS KIT	A10 A11		1	B,C
P1	GE34013-001A	CARTON			1	B,C
P2	GE10278-001A	CUSHION FRONT			1	B,C
P3	GE10279-001A	CUSHION BACK			1	B,C
P4	QPC03504015PB	POLY BAG	35cm x 40cm		1	B,C
P5	GE40467-003A	NON WOVEN SHEET			1	B,C
P6	FSPG4002-001	POLY BAG			2	B
P6	FSPG4002-001	POLY BAG			1	C
P8	QPA00801205	POLY BAG	8cm x 12cm		1	B,C
P9	QPC01603015	POLY BAG	16cm x 30cm		1	B,C
P10	FSPG4002-001	POLY BAG			1	B,C
P11	QPC01002515	POLY BAG	10cm x 25cm		1	B,C